

Chapter-

6

APPLICATION OF DERIVATIVES

Rate of change of bodies

Derivative as a rate measure

Introduction:

In this section, we shall study the physical meaning of the derivative $\frac{dy}{dx}$ and then

Apply it to some real-life situations

Rate of change of Quantities:

Let, $y = f(x)$ be a function of x .

ODM
EDUCATIONAL

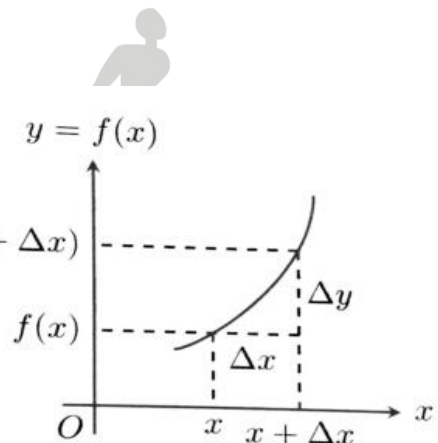

Let, Δx be the change in x , and Δy corresponding to a small change in y . (Δx and Δy are called increments)

Then $\Delta y = f(x + \Delta x) - f(x)$

Now, the average rate of change of y with respect to $x = \frac{\Delta y}{\Delta x}$

and instantaneous rate of change of y w. r. t. $x = \lim_{\Delta x \rightarrow 0} \frac{\Delta y}{\Delta x}$

Since $\frac{dy}{dx} = f'(x) = \lim_{\Delta x \rightarrow 0} \frac{f(x + \Delta x) - f(x)}{\Delta x} = \lim_{\Delta x \rightarrow 0} \frac{\Delta y}{\Delta x}$

$\therefore \frac{dy}{dx} =$ Instantaneous rate of change of y w. r. t. x

We write the rate of change of y with respect to x instead of 'instantaneous rate of change of y w. r. t. x

Hence, $\frac{dy}{dx} =$ the rate of change of y w. r. t. x

Problems on the rate change

Problem-1

Find the rate change of the area of the circle w. r. t. its radius. How fast is the area changing with respect to the radius when the radius is 3cm?

Answer:

Let r be the radius of the circle and A be the area of the circle.

$$\text{So, } A = \pi r^2$$

Differentiating w. r. t. r we get

$$\frac{dA}{dr} = \frac{d\pi r^2}{dr} \Rightarrow \frac{dA}{dr} = 2\pi r \text{ which is the rate of change of area w. r. t. } r.$$

When $r = 3$ cm, we obtain

$$\left. \frac{dA}{dr} \right|_{r=3} = (2\pi \times 3) \text{ cm} = 6\pi \text{ cm}$$

Problem-2

The total cost $C(x)$ associated with the production of x units of an item given by

$$C(x) = 0.005x^3 - 0.02x^2 + 30x + 5000$$

Find the marginal cost when 3 units are produced, where the marginal cost means the instantaneous rate of change of total cost at any level of output.

Answer:

Since marginal cost is the rate of change of total cost with respect to the output

$$\text{Marginal cost (MC)} = \frac{d}{dx}(C(x)) = \frac{d}{dx}(0.005x^3 - 0.02x^2 + 30x + 5000)$$

$$= 0.005(3x^2) - 0.02(2x) + 30$$

When $x = 3$ we get

$$\text{Marginal cost (MC)} = 0.005 \times 3 \times 3^2 - 0.02 \times 2 \times 3 + 30 = 0.135 - 0.12 + 30 = 30.015$$

Hence the required marginal cost is 30.02 rupees. (approximately)

Problem-3

A particle moves along the curve $6y = x^3 + 2$. Find the point on the curve at which the y-coordinate is changing 8 times as fast as the x-coordinate.

Answer:

Given curve is $6y = x^3 + 2$ -----(1)

A.T.Q. y- coordinate is changing 8 times as fast as the x- coordinate.

Therefore, $\frac{dy}{dt} = 8 \frac{dx}{dt}$ -----(2)

Now differentiating equation (1) w.r.t. 't' we get

$$6 \frac{dy}{dt} = \frac{dx^3}{dx} \times \frac{dx}{dt}$$

$$\Rightarrow 48 \frac{dx}{dt} = 3x^2 \frac{dx}{dt} \Rightarrow 48 = 3x^2$$

$$\Rightarrow x^2 = 16 \Rightarrow x = \pm 4$$

When $x = 4 \Rightarrow y = -4$

$x = -4 \Rightarrow y = -\frac{31}{3}$, hence points on the curve $(4, -4)$ & $(-4, -\frac{31}{3})$

Problem- 4

A ladder 5cm long is leaning against a wall. The bottom of the ladder is pulled along the ground, away from the wall, at the rate of 2 cm/sec. How fast does its height on the wall decrease when the foot of the ladder is 4cm away from the wall?

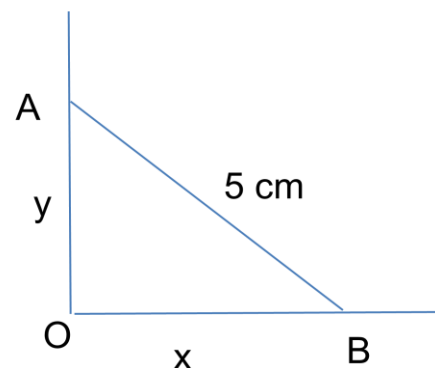

Answer: Let OB (length of ground from the wall) = x cm,

OA (length of the wall from the ground)= y cm

Given AB(length of the ladder)=5cm.

By Pythagoras theorem, we have $x^2 + y^2 = 25$ -----(1)

Again given that $\frac{dx}{dt} = 2 \text{ cm}$

Now differentiating equation (1) with respect to 't' we get

$$\frac{dx^2}{dt} + \frac{dy^2}{dt} = 0 \Rightarrow \frac{dx^2}{dx} \times \frac{dx}{dt} + \frac{dy^2}{dy} \times \frac{dy}{dt} = 0$$

$$\Rightarrow 2x \frac{dx}{dt} + 2y \frac{dy}{dt} = 0 \Rightarrow 2x \cdot 2 + 2y \frac{dy}{dt} = 0 \Rightarrow \frac{dy}{dt} = -\frac{2x}{y}$$

From equation (1) when x=4 then y=3

$$\Rightarrow \frac{dy}{dt} = -\frac{8}{3} \text{ so, the height of the wall decreases at the rate } \frac{8}{3} \text{ cm/sec.}$$

Problem-5

Sand is pouring from a pipe at the rate of $12\text{m}^3/\text{s}$. The falling sand forms a cone on the ground in such a way that the height of the cone is always one-sixth of the radius of the base. How fast does the height of the sand cone increase with the height being 4 cm?

Answer:

Consider the height and radius of the sand-cone formed at time t second by y cm and x cm respectively.

As per the given statement $y = \frac{1}{6}x \Rightarrow x = 6y$

The volume of the cone (v) = $\frac{1}{3}\pi x^2 y = \frac{1}{3}\pi(6y)^2 y = 12\pi y^3$

$$\Rightarrow \frac{dv}{dy} = 36\pi y^2$$

Now, As $\frac{dv}{dt} = 12$

So, $\frac{dv}{dy} \times \frac{dy}{dt} = 12 \Rightarrow 36\pi y^2 \frac{dy}{dt} = 12$

$$\Rightarrow \frac{dy}{dt} = \frac{1}{3\pi 4^2} = \frac{1}{48\pi} \text{ cm/sec} \quad (\text{as } y = 4\text{cm})$$

which is a height increment.

Problem-6

The length of the rectangle is decreasing at the rate of 3 cm/ minute and the width y is increasing at the rate of 2cm/minute. When $x = 10$ cm and $y = 6$ cm , find the rate change of

- (a) The perimeter (b) The area of the rectangle.

Answer:

Since the length x is decreasing and the width y is increasing w. r. t. time, we have

$$\frac{dx}{dt} = -3\text{cm/min} \text{ and } \frac{dy}{dt} = 2\text{cm/min}$$

- (a) The perimeter P of the rectangle is given by

$$P = 2(x + y) \Rightarrow \frac{dP}{dt} = 2\left(\frac{dx}{dt} + \frac{dy}{dt}\right) = 2(-3 + 2) = -2\text{cm/min}$$

- (b) The area A of the rectangle is given by

$$A = x \cdot y$$

$$\Rightarrow \frac{dA}{dt} = \frac{dx}{dt} y + x \frac{dy}{dt} = -3(6) + 10(2) = 2\text{cm}^2/\text{min} \quad (\text{As } x = 10\text{cm}, y = 6\text{cm})$$

Increasing and Decreasing Functions

In this topic, we shall study, A function $f(x)$ is said to be increasing or decreasing on $[a, b]$ if

- (i) The value of $f(x)$ increases with an increase in x .

OR

- (ii) The value of $f(x)$ decreases with the decrease in x .

Definition

Increasing Function:-

Let I be an open interval contained in the domain of real-valued function f , then f is said to be

- (i) Increasing (\uparrow) on I , if $x_1 < x_2 \Rightarrow f(x_1) \leq f(x_2)$, for all $x_1, x_2 \in I$
- (ii) Strictly increasing on I if $x_1 < x_2 \Rightarrow f(x_1) < f(x_2)$, for all $x_1, x_2 \in I$

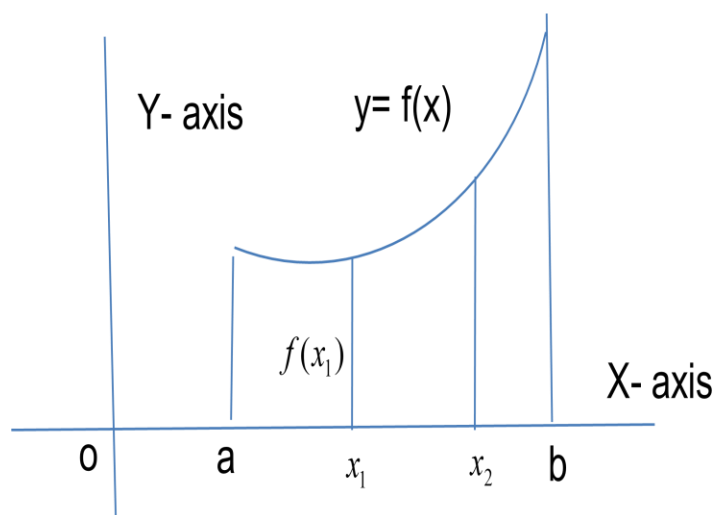

Decreasing Function:-

Let I be an open interval contained in the domain of real-valued function f , Then f is said to be

- (i) Decreasing (\downarrow) on I , if $x_1 < x_2 \Rightarrow f(x_1) \geq f(x_2)$, for all $x_1, x_2 \in I$
- (ii) strictly decreasing on I if $x_1 < x_2 \Rightarrow f(x_1) > f(x_2)$, for all $x_1, x_2 \in I$

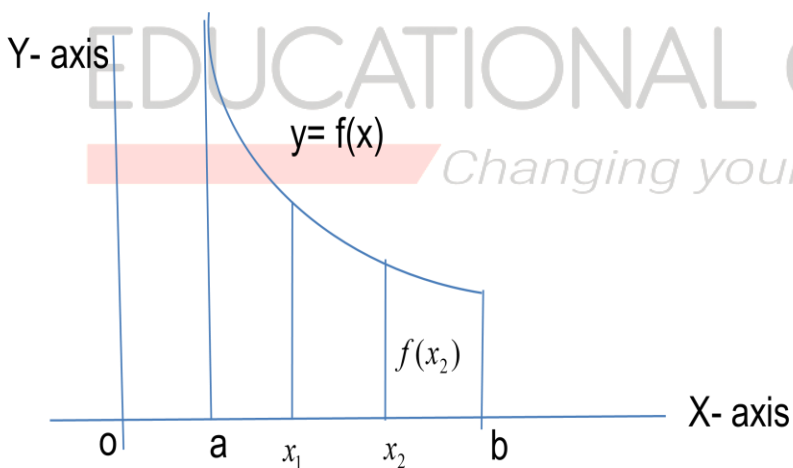

Monotonic Function (Increasing or decreasing of a Function on an interval)

A function $f(x)$ is said to be monotonic on an interval (a, b) if it is either increasing or decreasing on (a, b) .

NECESSARY AND SUFFICIENT CONDITIONS FOR MONOTONICITY

Now, we see how to determine the function increasing and decreasing using the derivative of a function.

NECESSARY CONDITION

Let $f(x)$ is continuous on $[a, b]$ and differentiable on (a, b) .

(i) If $f(x)$ is strictly increasing on (a, b) then $f'(x) > 0$ for all $x \in (a, b)$

(ii) If $f(x)$ is strictly decreasing on (a, b) then $f'(x) < 0$ for all $x \in (a, b)$

SUFFICIENT CONDITION

Let $f(x)$ be a differentiable function defined on an open interval (a, b)

(i) If $f'(x) > 0$ for all $x \in (a, b)$ then $f(x)$ is increasing on (a, b) .

(ii) If $f'(x) < 0$ for all $x \in (a, b)$ then $f(x)$ is decreasing on (a, b) .

Working rules for finding out the interval for increasing and decreasing function.**Step-1**

Find out $\frac{dy}{dx}$ of the given function.

Step-2

If $\frac{dy}{dx} > 0$ then, the function is an increasing function.

If $\frac{dy}{dx} < 0$ then, the function is decreasing function.

Problems**Problem- 1**

Find the intervals in which the function $y = 2x^2 - 3x$ is increasing or decreasing.

Answer:

The given function is $y = 2x^2 - 3x$

Differentiating w. r. t. 'x' both sides we get.

$$\frac{dy}{dx} = 4x - 3$$

For increasing, let $\frac{dy}{dx} > 0 \Rightarrow 4x - 3 > 0 \Rightarrow x > \frac{3}{4}$

Hence, the function is increasing on $\left(\frac{3}{4}, \infty\right)$

For decreasing, let $\frac{dy}{dx} < 0 \Rightarrow 4x - 3 < 0 \Rightarrow x < \frac{3}{4}$

Hence, the function is decreasing on $\left(-\infty, \frac{3}{4}\right)$

Problem- 2

Find the intervals in which the function $y = -2x^3 - 9x^2 - 12x + 1$ is increasing or decreasing.

Answer:

The given function is $y = -2x^3 - 9x^2 - 12x + 1$

Differentiating w. r. t. 'x' both sides we get.

$$\frac{dy}{dx} = -6x^2 - 18x - 12 \Rightarrow \frac{dy}{dx} = -6(x^2 + 3x + 2) \Rightarrow \frac{dy}{dx} = -6(x+2)(x+1)$$

Let $\frac{dy}{dx} = 0 \Rightarrow -6(x+2)(x+1) = 0 \Rightarrow x = -1, -2$



When $x \in (-\infty, -2)$

$\Rightarrow \frac{dy}{dx} = -6(x+2)(x+1)$ is negative, hence given function is decreasing.
 $(-)$ $(-)$ $(-)$

When $x \in (-2, -1)$

$\Rightarrow \frac{dy}{dx} = -6(x+2)(x+1)$ is positive, hence given function is increasing.
 $(-)$ $(-)$ $(+)$

When $x \in (-1, \infty)$

$\Rightarrow \frac{dy}{dx} = -6(x+2)(x+1)$ is negative, hence given function is decreasing.

(-) (+) (+)

From the above observation given function is increasing on $(-2, -1)$ and decreasing on $(-\infty, -2) \cup (-1, \infty)$

Problem- 3

Find the intervals in which the function $y = (x+1)^3(x-3)^3$ is increasing or decreasing.

Answer:

The given function is $y = (x+1)^3(x-3)^3$

Differentiating w. r. t. 'x' both sides we get.

$$\frac{dy}{dx} = (x+1)^3 \cdot 3(x-3)^2 + (x-3)^3 \cdot 3(x+1)^2$$

$$\Rightarrow \frac{dy}{dx} = 3(x-3)^2(x+1)^2(2x-2) \Rightarrow \frac{dy}{dx} = 6(x-3)^2(x+1)^2(x-1)$$

For increasing

$$\frac{dy}{dx} > 0 \Rightarrow 6(x-3)^2(x+1)^2(x-1) > 0 \Rightarrow (x-1) > 0 \Rightarrow x > 1$$

But not equal to 3

For decreasing

$$\frac{dy}{dx} < 0 \Rightarrow 6(x-3)^2(x+1)^2(x-1) < 0 \Rightarrow (x-1) < 0 \Rightarrow x < 1$$

But not equal to -1

Hence function is increasing on $(1, \infty) - \{3\}$ and decreasing $(-\infty, 1) - \{-1\}$

Problem- 4

Show that the function f given by $f(x) = x^3 - 3x^2 + 4x$, $x \in R$ is strictly increasing on R.

Answer:

Given function $f(x) = x^3 - 3x^2 + 4x$, $x \in R$

Now $f'(x) = 3x^2 - 6x + 4 \quad \forall x \in R$

$$\Rightarrow f'(x) = 3\left(x^2 - 2x + \frac{4}{3}\right)$$

$$\Rightarrow f'(x) = 3\left(x^2 - 2 \times 1 \times x + 1^2 - 1 + \frac{4}{3}\right)$$

$$\Rightarrow f'(x) = 3\left((x-1)^2 + \frac{1}{3}\right) > 0,$$

Hence the function is strictly increasing on the R set.

Problem- 5

Find the intervals in which the function is given by $f(x) = \sin 3x$, $x \in \left[0, \frac{\pi}{2}\right]$

Answer:

Given function $f(x) = \sin 3x$, $x \in \left[0, \frac{\pi}{2}\right]$

Now $f'(x) = 3 \cos 3x$

Let $f'(x) = 3 \cos 3x = 0 \Rightarrow \cos 3x = 0$

Here for the general solution

$$\cos 3x = 0 \Rightarrow 3x = (2n+1)\frac{\pi}{2}, \quad n \in Z$$

$$\Rightarrow x = (2n+1)\frac{\pi}{6}, \quad n \in Z \quad \text{When } n=0 \Rightarrow x = \frac{\pi}{6}$$



When $x \in \left[0, \frac{\pi}{6}\right)$

$f'(x) = 3 \cos 3x$ is increasing function.

When $x \in \left(\frac{\pi}{6}, \frac{\pi}{2}\right]$

$f'(x) = 3 \cos 3x$ is decreasing function

Problem- 6

Find the intervals in which the function given by $f(x) = \sin x + \cos x$, $x \in [0, 2\pi]$ is strictly increasing or decreasing.

Answer:

Given function $f(x) = \sin x + \cos x$, $x \in [0, 2\pi]$

Now $f'(x) = \cos x - \sin x$

$$\Rightarrow f'(x) = \cos x - \sin x = 0$$

$$\Rightarrow \tan x = 1 = \tan \frac{\pi}{4}$$

Here the general solution is $x = n\pi + \frac{\pi}{4}$, $n \in \mathbb{Z}$



When $n=0 \Rightarrow x = \frac{\pi}{4}$ when $n=1 \Rightarrow x = \frac{5\pi}{4}$

Hence intervals are $\left[0, \frac{\pi}{4}\right)$, $\left(\frac{\pi}{4}, \frac{5\pi}{4}\right)$, $\left(\frac{5\pi}{4}, 2\pi\right]$

Given function is positive on $\left[0, \frac{\pi}{4}\right)$, and $\left(\frac{5\pi}{4}, 2\pi\right]$, negative on $\left(\frac{\pi}{4}, \frac{5\pi}{4}\right)$,

Therefore $f(x)$ is increasing on $\left[0, \frac{\pi}{4}\right) \cup \left(\frac{5\pi}{4}, 2\pi\right]$

And decreasing on $\left(\frac{\pi}{4}, \frac{5\pi}{4}\right)$,

Problem- 7

Show that $y = \log(1+x) - \left(\frac{2x}{2+x}\right)$, $x > -1$ is an increasing function of x throughout its domain.

Answer:

Given function $y = \log(1+x) - \left(\frac{2x}{2+x}\right)$, $x > -1$

$$\Rightarrow \frac{dy}{dx} = \left(\frac{1}{1+x}\right) - \left\{\frac{(2+x)2 - 2x}{(2+x)^2}\right\}$$

$$\Rightarrow \frac{dy}{dx} = \left(\frac{1}{1+x}\right) - \left\{\frac{4+2x-2x}{(2+x)^2}\right\}$$

$$\Rightarrow \frac{dy}{dx} = \left(\frac{1}{1+x}\right) - \left\{\frac{4}{(2+x)^2}\right\}$$

$$\begin{aligned} \Rightarrow \frac{dy}{dx} &= \frac{(2+x)^2 - 4(1+x)}{(1+x)(2+x)^2} \\ \Rightarrow \frac{dy}{dx} &= \frac{4+x^2+4x-4-4x}{(1+x)(2+x)^2} \\ \Rightarrow \frac{dy}{dx} &= \frac{(x)^2}{(1+x)(2+x)^2} > 0, \text{ when } x > -1 \end{aligned}$$

Hence, the given function is increasing throughout its domain.

Problem- 8

Show that $y = \frac{4 \sin \theta}{2 + \cos \theta} - \theta$ is increasing function of θ in $\left[0, \frac{\pi}{2}\right]$

Answer:

Given function $y = \frac{4 \sin \theta}{2 + \cos \theta} - \theta$

$$\Rightarrow \frac{dy}{d\theta} = \frac{(2 + \cos \theta)4 \cos \theta + 4 \sin \theta \sin \theta}{(2 + \cos \theta)^2} - 1$$

$$\Rightarrow \frac{dy}{d\theta} = \frac{8 \cos \theta + 4 \cos^2 \theta + 4 \sin^2 \theta}{(2 + \cos \theta)^2} - 1$$

$$\Rightarrow \frac{dy}{d\theta} = \frac{8 \cos \theta + 4 - 4 - \cos^2 \theta - 4 \cos \theta}{(2 + \cos \theta)^2}$$

$$\Rightarrow \frac{dy}{d\theta} = \frac{4 \cos \theta - \cos^2 \theta}{(2 + \cos \theta)^2}$$

$$\Rightarrow \frac{dy}{d\theta} = \frac{\cos \theta (4 - \cos \theta)}{(2 + \cos \theta)^2} > 0, \quad \forall, \theta \in \left[0, \frac{\pi}{2}\right]$$

Hence, the given function is an increasing function.

TANGENTS AND NORMALS

INTRODUCTION

In this topic, we shall use the derivative of the function $y = f(x)$ to find the equation of tangent and normal to the curve at a given point

Slope or Gradient of a line:

If a line makes an angle θ with the positive direction of the x-axis in the anticlockwise direction,

Then $\tan \theta$ is called the slope of the line.

The slope of the line perpendicular to the x-axis is not defined.

The slope of the line parallel to the x-axis is zero.

Equation of Tangent and Normal at a point to a curve:

Let $y = f(x)$ be a curve and $P(\alpha, \beta)$ be a point on it.

Then we know that slope of the tangent to the curve $y = f(x)$

at the point $P(\alpha, \beta)$ is given by $\left(\frac{dy}{dx}\right)_{at(\alpha, \beta)} = f'(\alpha)$

Equation of tangent at a point:

As we know that the equation of a line passing through the point (α, β) having slope m is

$$y - \beta = m(x - \alpha)$$

Therefore the equation of the tangent to the curve $y = f(x)$ at $P(\alpha, \beta)$ is

$$y - \beta = \left(\frac{dy}{dx}\right)_{at(\alpha, \beta)} (x - \alpha)$$

$$\text{or } y - \beta = f'(\alpha)(x - \alpha)$$

Equation of normal at a point:

We know that normal to the curve at the point P is a line perpendicular to the tangent at P.

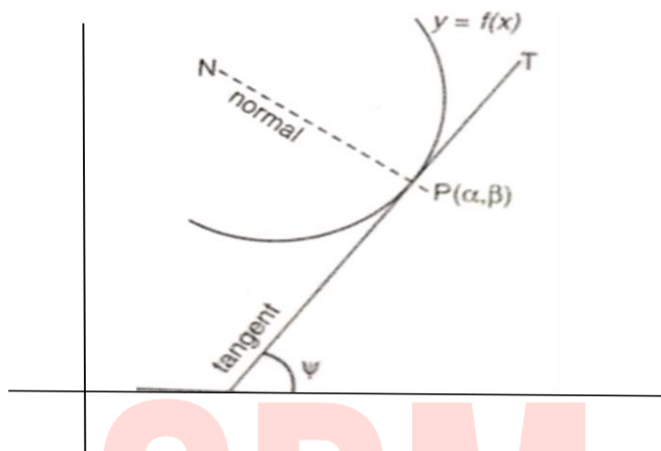

Hence the slope of the normal to the curve $y = f(x)$ at $P = \frac{-1}{\left(\frac{dy}{dx}\right)_{at(\alpha, \beta)}} = \frac{1}{f'(\alpha)}$

Equation of the normal to the curve $y = f(x)$ at $P(\alpha, \beta)$ is

$$y - \beta = \frac{-1}{\left(\frac{dy}{dx}\right)_{at(\alpha, \beta)}}(x - \alpha)$$

or
$$y - \beta = -\frac{1}{f'(\alpha)}(x - \alpha)$$

Working Rule:

Step I. Find $\frac{dy}{dx}$ from the equation of the given curve

Step II. If the equation of the tangent and normal at (α, β) is needed, find $\frac{dy}{dx}$ at (α, β) . This value of $\frac{dy}{dx}$ will be the slope of the tangent at (α, β)

$$\text{the slope of normal at } (\alpha, \beta) = \frac{-1}{\text{slope of tangent at } (\alpha, \beta)}$$

Step III. If the value of $\frac{dy}{dx}$ at (α, β) be m , the equation of normal and tangent at (α, β) will be

$$(a) \quad y - \beta = m(x - \alpha)$$

$$(b) \quad y - \beta = \frac{-1}{m}(x - \alpha)$$

Step IV. If at a point $P(\alpha, \beta)$'s zero then the tangent is parallel to the x-axis

If $\frac{dy}{dx}$ is at $P(\alpha, \beta)$'s undefined then the tangent at $P(\alpha, \beta)$'s parallel to y-axis and

Normal at $P(\alpha, \beta)$ is parallel to the x-axis. In this case equation of the tangent at P will be and that of normal will be $y = \beta$

PROBLEMS

Problem: 1

Find the slope of the tangent to the curve $y^2 = x$ at the point $x = 1$.

Ans: Given curve is $y^2 = x$ -----(1)

Given point is $x = 1$

From (1), when $x = 1, y^2 = 1 \therefore y = \pm 1$

\therefore Points are $(1, 1)$ and $(1, -1)$

Differentiating both sides of (1) w.r. to x , we get

$$2y \frac{dy}{dx} = 1 \quad \therefore \frac{dy}{dx} = \frac{1}{2y}$$

$$\therefore \text{at } (1, 1), \frac{dy}{dx} = \frac{1}{2 \times 1} = \frac{1}{2} \quad \text{and} \quad \text{at } (1, -1), \frac{dy}{dx} = \frac{1}{2(-1)} = -\frac{1}{2}$$

Hence slope of tangents at points $(1, 1)$ and $(1, -1)$ are $\frac{1}{2}$ and $-\frac{1}{2}$ respectively.

Problem: 2

Find the equation of the tangent and normal to the curve $y = x^2 + 4x + 1$ at the point whose x-coordinate is 3.

Ans:

The given curve is $y = x^2 + 4x + 1$

When $x = 3, y = 3^2 + 4 \times 3 + 1 = 22$

We want to find the tangent and normal to curve (1) at the point $P(3, 22)$.

Differentiating (1) w.r.t. x , we get

$$\frac{dy}{dx} = 2x + 4$$

$$\Rightarrow \left(\frac{dy}{dx}\right)_P = 2 \times 3 + 4 = 10$$

\therefore Equation of the tangent to (1) at $P(3, 22)$ is

$$y - 22 = 10(x - 3)$$

or $y = 10x - 8$

Equation of the normal to (1) at P is

$$y - 22 = -\frac{1}{10}(x - 3)$$

or $10y - 220 = -x + 3$

or $x + 10y = 223$

Problem:3

Find the points on the curve $y = x^3 - x^2 - x + 3$, where the tangent is parallel to the x -axis.

Given curve is $y = x^3 - x^2 - x + 3$

$$\frac{dy}{dx} = 3x^2 - 2x - 1$$

Since the tangent is parallel to x -axis

$$\therefore \frac{dy}{dx} = \tan 0^\circ = 0$$

$$3x^2 - 2x - 1 = 0$$

or $3x^2 - 3x + x - 1 = 0$, or $(3x + 1)(x - 1) = 0$

$$\therefore x = 1, -\frac{1}{3}$$

Putting the values of x in (1), we have

when $x = 1, y = 1^3 - 1^2 - 1 + 3 = 2$,

when $x = -\frac{1}{3}, y = -\frac{1}{27} - \frac{1}{9} + \frac{1}{3} + 3 = 3\frac{5}{27}$

Hence required points are $(1, 2)$ and $\left(-\frac{1}{3}, 3\frac{5}{27}\right)$.

Problem:4

At what point on the curve $x^2 + y^2 - 2x - 4y + 1 = 0$, is the tangent parallel to the y-axis.

Solution:

$$2x + 2y \cdot \frac{dy}{dx} - 2 - 4 \frac{dy}{dx} = 0$$

$$\Rightarrow (y - 2) \frac{dy}{dx} = 1 - x$$

$$\Rightarrow \frac{dy}{dx} = \frac{1 - x}{y - 2}$$

For tangents to be parallel to y-axis,
 $\frac{dy}{dx}$ is undefined $\Rightarrow \frac{1 - x}{y - 2}$ is undefined $\Rightarrow y = 2$

Substituting for y in (1), we get

$$x^2 + 4 - 2x - 8 + 1 = 0$$

$$\Rightarrow x^2 - 2x - 3 = 0$$

$$\Rightarrow x = 3, -1$$

\therefore At points (3, 2) and (-1, 2), the tangents to curve (1) are parallel to y-axis.

Problem:5

Find the equations of tangents to the curve $y = x^3 + 2x + 6$ which is perpendicular to the line $x + 14y + 4 = 0$

Solution:

The given curve is $y = x^3 + 2x + 6$ ----- (1)

$$\Rightarrow \frac{dy}{dx} = 3x^2 + 2$$

We have to find the equation of tangents which

are perpendicular to the line $x + 14y + 4 = 0$ ----- (3)

Now slope of this line $= -\frac{1}{14}$

\therefore Slope of the tangent $= 14$.

Using (2), we get

$$3x^2 + 2 = 14 \Rightarrow x^2 = 4 \Rightarrow x = \pm 2$$

From (1), $x = 2 \Rightarrow y = 2^3 + 2 \times 2 + 6 = 18$

and $x = -2 \Rightarrow y = (-2)^3 + 2 \times (-2) + 6 = -6$

\therefore Tangents to (1) are to be drawn at $P(2, 18)$

and $Q(-2, -6)$ with slope 14.

Their equations are

$$y - 18 = 14(x - 2) \Rightarrow 14x - y = 10$$

$$y + 6 = 14(x + 2) \Rightarrow 14x - y + 22 = 0$$

Problem:6

Find the equation of the tangent to the curve $x = 1 - \cos \theta, y = \theta - \sin \theta$ at $\theta = \frac{\pi}{4}$

Solution:

Given curve is $x = 1 - \cos \theta$
 $y = \theta - \sin \theta$

$$\therefore \frac{dy}{d\theta} = 1 - \cos \theta$$

$$\text{and } \frac{dx}{d\theta} = \sin \theta$$

$$\text{Now, } \frac{dy}{dx} = \frac{\frac{dy}{d\theta}}{\frac{dx}{d\theta}} = \frac{1 - \cos \theta}{\sin \theta}$$

$$\text{At } \theta = \frac{\pi}{4}; \quad \frac{dy}{dx} = \frac{1 - \cos \frac{\pi}{4}}{\sin \frac{\pi}{4}} = \frac{1 - \frac{1}{\sqrt{2}}}{\frac{1}{\sqrt{2}}} = \sqrt{2} - 1$$

$$\text{When } \theta = \frac{\pi}{4}, x = 1 - \cos \frac{\pi}{4} = 1 - \frac{1}{\sqrt{2}}$$

$$\text{and } y = \frac{\pi}{4} - \sin \frac{\pi}{4} = \frac{\pi}{4} - \frac{1}{\sqrt{2}}$$

Equation of tangent at $\theta = \frac{\pi}{4}$ i.e., at point $\left(1 - \frac{1}{\sqrt{2}}, \frac{\pi}{4} - \frac{1}{\sqrt{2}}\right)$ is

$$y - \frac{\pi}{4} + \frac{1}{\sqrt{2}} = (\sqrt{2} - 1) \left(x - 1 + \frac{1}{\sqrt{2}}\right)$$

$$\text{or } y - \frac{\pi}{4} + \frac{1}{\sqrt{2}} = (\sqrt{2} - 1)x - (\sqrt{2} - 1) + \left(\frac{\sqrt{2} - 1}{\sqrt{2}}\right)$$

$$\text{or } y - \frac{\pi}{4} + \frac{1}{\sqrt{2}} = (\sqrt{2} - 1)x + 2 - \frac{3}{\sqrt{2}}$$

$$\text{or } y = (\sqrt{2} - 1)x + \frac{\pi}{4} + 2 - 2\sqrt{2}.$$

Problem:7

Find the equation of the normal to the curve $4y = x^2$ which passes through the point (1,2).

Solution: The given curve is $4y = x^2$. ----- (1)

Let the point of contact of the required normal with the given curve be (α, β)

hence $4\beta = \alpha^2$ ----- (2)

Differentiating both sides w.r.t. x we get

$$4 \frac{dy}{dx} = 2x \Rightarrow \frac{dy}{dx} = \frac{x}{2}$$

$$\Rightarrow \left(\frac{dy}{dx} \right)_{(\alpha, \beta)} = \frac{\alpha}{2}$$

Now the equation of the normal at (α, β) is

$$y - \beta = -\frac{1}{\left(\frac{dy}{dx} \right)_{(\alpha, \beta)}} (x - \alpha)$$

i.e. $y - \beta = -\frac{2}{\alpha} (x - \alpha)$ ----- (3)

Given that normal line passes through the point (1, 2).

$$\therefore 2 - \beta = -\frac{2}{\alpha} (1 - \alpha)$$

$$\Rightarrow 2 - \frac{\alpha^2}{4} = -\frac{2}{\alpha} (1 - \alpha)$$

$$\Rightarrow 8\alpha - \alpha^3 = -8 + 8\alpha$$

$$\Rightarrow \alpha^3 = 8$$

$$\Rightarrow \alpha = 2$$

Putting $\alpha = 2$ in (2), we get $\beta = 1$.

Putting $\alpha = 2$ and $\beta = 1$ in (3), we get

Equation of normal at (2, 1) is $y - 1 = -(x - 2)$, i.e., $x + y = 3$.

Problem:8

Show that the curves $2x = y^2$ and $2xy = k$ cut at right angles if $k^2 = 8$.

SOLUTION : Given curves are $2x = y^2$... (1)

and $2xy = k$... (2)

From (1), $2 = 2y \frac{dy}{dx}$ or $\frac{dy}{dx} = \frac{1}{y}$... (3)

From (2), $y = \frac{k}{2x} \quad \therefore \frac{dy}{dx} = -\frac{k}{2x^2}$... (4)

Putting the value of y from (2) in (1), we get

$$2x = \frac{k^2}{4x^2} \quad \text{or} \quad 8x^3 = k^2 \quad \therefore \quad x = \left(\frac{k^2}{8}\right)^{\frac{1}{3}} = \frac{k^{\frac{2}{3}}}{2}$$

From (2), $y = \frac{k}{2x} = \frac{k}{2} \cdot \frac{2}{k^{\frac{2}{3}}} = k^{\frac{1}{3}}$

From (2), $y = \frac{k}{2x} = \frac{k}{2} \cdot \frac{2}{k^{\frac{2}{3}}} = k^{\frac{1}{3}}$

Hence point of intersection of curves (1) and (2) is $P\left(\frac{k^{\frac{2}{3}}}{2}, k^{\frac{1}{3}}\right)$

From (3), at $P\left(\frac{k^{\frac{2}{3}}}{2}, k^{\frac{1}{3}}\right)$, $\frac{dy}{dx} = \frac{1}{k^{\frac{1}{3}}} = m_1$ (say)

From (4), at $P\left(\frac{k^{\frac{2}{3}}}{2}, k^{\frac{1}{3}}\right)$, $\frac{dy}{dx} = -\frac{k}{2} \cdot \frac{4}{k^{\frac{4}{3}}} = -\frac{2}{k^{\frac{1}{3}}} = m_2$ (say)

Now $m_1 m_2 = \frac{1}{k^{\frac{1}{3}}} \left(-\frac{2}{k^{\frac{1}{3}}}\right) = -\frac{2}{k^{\frac{2}{3}}}$

The two curves (1) and (2) will cut at right angles if

$$m_1 m_2 = -1 \quad \text{or} \quad \text{if} \quad -\frac{2}{k^{\frac{2}{3}}} = -1 \quad \text{or} \quad k^{\frac{2}{3}} = 2 \quad \text{or} \quad k^2 = 8.$$

Use of Derivative in Approximation

Differentials: -

Let $y = f(x)$ be a differential function of a function of x . and let Δx be a small change in x and let the corresponding change in y be Δy . We defined.

(a) The differential of x , denoted by dx is given by $dx \cong \Delta x$.

(b) The differential of y , denoted by dy , is given by $dy = f'(x) dx$

In case $dx = \Delta x$ is very small in comparison to x then. $dy \cong \Delta y$

$$\therefore \Delta y = \frac{dy}{dx} \Delta x$$

Note :

Absolute Error :

The error Δx in x is called the absolute error in x .

Relative Error :

If Δx is an error in x , then, $\frac{\Delta x}{x}$ is called the relative error in x .

Percentage Error :

If Δx is an error in x , then $\frac{\Delta x}{x} \times 100$ is called the percentage error in x .

Remember:

Let $y = f(x)$ be a function of x , and let Δx be a small change in x . Let the corresponding change in y be, Δy then

$$y + \Delta y = f(x + \Delta x)$$

$$\text{But } \Delta y = \frac{dy}{dx} \cdot \Delta x = f'(x) \cdot \Delta x \quad (\text{approximately})$$

$$\therefore f(x + \Delta x) = y + f'(x) \times \Delta x \Rightarrow f(x + \Delta x) = y + f'(x) \times \Delta x \quad (\text{approximately})$$

$$\Rightarrow f(x + \Delta x) = f(x) + f'(x) \times \Delta x \quad (\text{approximately})$$

Example – 1

Use differential to approximate $\sqrt{36.6}$.

Answer:

Take $y = \sqrt{x}$. Let $x = 36$ and let $\Delta x = 0.06$ Then

$$\Delta y = \sqrt{x + \Delta x} - \sqrt{x} = \sqrt{36.6} - \sqrt{36} = \sqrt{36.6} - 6$$

$$\text{Or } \sqrt{36.6} = 6 + \Delta y$$

Now dy is approximately equal to Δy and is given by

$$dy = \left(\frac{dy}{dx} \right) \Delta x = \frac{1}{2\sqrt{x}} (0.6) = \frac{1}{2\sqrt{36}} (0.6) = 0.05$$

Thus the approximate value is $\sqrt{36.6}$ is $6 + 0.05 = 6.05$

Example – 2

Use differential to approximate $(25)^{\frac{1}{3}}$

Answer:

Let $y = x^{\frac{1}{3}}$. Let $x = 27$ and let $\Delta x = -2$. Then

$$\Delta y = (x + \Delta x)^{\frac{1}{3}} - x^{\frac{1}{3}} = (25)^{\frac{1}{3}} - (27)^{\frac{1}{3}} = (25)^{\frac{1}{3}} - 3$$

or $(25)^{\frac{1}{3}} = 3 + \Delta y$

Now dy is approximately equal to Δy and is given by

$$dy = \left(\frac{dy}{dx} \right) \Delta x = \frac{1}{3x^{\frac{2}{3}}} (-2) \quad (\text{as } y = x^{\frac{1}{3}})$$

$$= \frac{1}{3((27)^{\frac{1}{3}})^2} (-2) = \frac{-2}{27} = -0.074$$

Thus, the approximate value of $(25)^{\frac{1}{3}}$ is given by
 $3 + (-0.074) = 2.926$

Example- 3

Find the approximate value of $f(3.02)$, where $f(x) = 3x^2 + 5x + 3$

Answer:

Let $x = 3$ and $\Delta x = 0.02$. Then

$$f(3.02) = f(x + \Delta x) = 3(x + \Delta x)^2 + 5(x + \Delta x) + 3$$

Note that $\Delta y = f(x + \Delta x) - f(x)$. Therefore

$$\begin{aligned} f(x + \Delta x) &= f(x) + \Delta y \\ &\approx f(x) + f'(x) \Delta x \quad (\text{as } dx = \Delta x) \end{aligned}$$

or

$$\begin{aligned}
 f(3.02) &\approx (3x^2 + 5x + 3) + (6x + 5) \Delta x \\
 &= (3(3)^2 + 5(3) + 3) + (6(3) + 5) (0.02) \quad (\text{as } x = 3, \Delta x = 0.02) \\
 &= (27 + 15 + 3) + (18 + 5) (0.02) \\
 &= 45 + 0.46 = 45.46
 \end{aligned}$$

Hence, approximate value of $f(3.02)$ is 45.46.

Example - 4

If the radius of a sphere is measured as 9 cm with an error of 0.03 cm, then find the approximate error in calculating its volume.

Answer:

Let r be the radius of the sphere and Δr be the error in measuring the radius.

Then $r = 9$ cm and $\Delta r = 0.03$ cm. Now, the volume V of the sphere is given by

$$V = \frac{4}{3} \pi r^3$$

or

$$\frac{dV}{dr} = 4\pi r^2$$

Therefore

$$\begin{aligned}
 dV &= \left(\frac{dV}{dr} \right) \Delta r = (4\pi r^2) \Delta r \\
 &= 4\pi(9)^2 (0.03) = 9.72\pi \text{ cm}^3
 \end{aligned}$$

Thus, the approximate error in calculating the volume is $9.72\pi \text{ cm}^3$.

Example - 5

Find the approximate change in volume V of a cube of side x meters caused by increasing the side by 1%.

Answer:

The volume of the cube V of side x is given by $V = x^3$

$$dV = \left(\frac{dV}{dx} \right) \Delta x = 3x^2 \Delta x = 3x^2 (0.01)x = 0.03x^3$$

Because 1 percent of x is $0.01x$

Hence the approximate change in the volume of the cube is $0.03x^3 \text{ m}^3$



Maxima and Minima

First Derivative Test of Maxima and Minima

Local Maximum and minimum values of $y = f(x)$

Definition of local Maximum value:

A function $f(x)$ said to have a local maximum value at $x = a$, if $f(a)$ is greater than any other value that $f(x)$ can have in some suitably small neighborhood of $x = a$.

OR

A function is said to have local maximum value $f(a)$ at $x = a$ if $f(x)$ stop to increase at $x = a$ and begins to decrease as x increases beyond a .

Definition of Local Minimum value:

A function $f(x)$ said to have a local minimum value at $x = a$, if $f(a)$ is less than any other value that $f(x)$ can have in some suitably small neighborhood of $x = a$.

OR

A function is said to have local minimum value $f(a)$ at $x = a$ if $f(x)$ stop to decrease at $x = a$ and begins to increase as x increases beyond a .

First Derivative Test for Local Maxima Of a Function

Function $f(x)$ has a local maximum value at $x = a$, if $f(x)$ stops to increase at $x = a$ and begins to decrease as x increases beyond 'a'.

Thus when x is slightly less than 'a', y increases and $\frac{dy}{dx}$ is +ve

When x is slightly greater than 'a', y decreases and $\frac{dy}{dx}$ is -ve

Therefore $\frac{dy}{dx}$ changes its sign from +ve to -ve as x passes through the Value 'a'. But it can not change sign without passing through the value zero which must evidently be attained at $x = a$.

Hence, we have the following two conditions for $y=f(x)$ to have a

A local Maximum value $f(a)$ at $x = a$.

(i) $\frac{dy}{dx} = 0$ at $x = a$.

(ii) $\frac{dy}{dx}$ changes its sign from +ve to -ve as x passes through the value a .

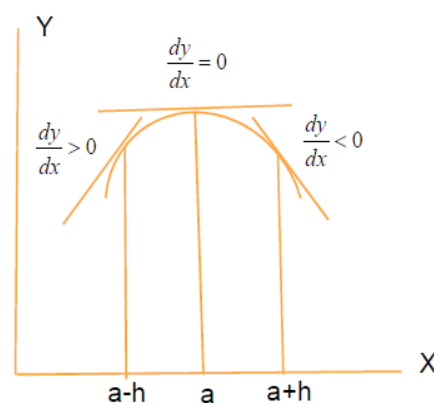

First Derivative Test For Local Minima Of a Function

Function $f(x)$ has a local minimum value at $x = a$, if $f(x)$ stops to decrease at $x = a$ and begins to increase as x increases beyond 'a'.

Thus when x is slightly less than 'a', y increases and $\frac{dy}{dx}$ is +ve

When x is slightly greater than 'a', y decreases and $\frac{dy}{dx}$ is -ve

Therefore $\frac{dy}{dx}$ changes its sign from +ve to -ve as x passes through the Value 'a'. But it can not change sign without passing through the value zero which must evidently be attained at $x = a$.

Hence, we have the following two conditions for $y=f(x)$ to have a

A local Maximum value $f(a)$ at $x = a$.

(i) $\frac{dy}{dx} = 0$ at $x = a$.

(ii) $\frac{dy}{dx}$ changes its sign from +ve to -ve as x passes through the value a .

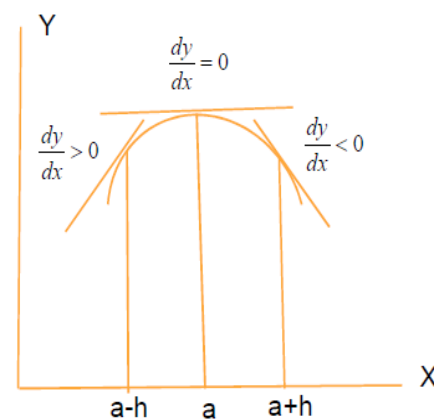

Working Rules For the First Derivative Test

Step-1

Find $\frac{dy}{dx}$ of the given function.

Step-2

let $\frac{dy}{dx} = 0$ for critical points (say $x = a, b, c, \dots$), (remember the critical point is the point where the derivative of the function is equal to zero.)

Step-3

(i) If $\frac{dy}{dx}$ changes its sign from +ve to -ve as x passes through the values 'a, b, c, ...' then function attain the maximum value.

(ii) If $\frac{dy}{dx}$ changes its sign from -ve to +ve as x passes through the values 'a, b, c, ...' then function attain the minimum value.

Problems

Problem-1

Find all points of local maxima and local minima of the function given by $f(x) = x^3 - 3x + 3$

Answer:

Given function $f(x) = x^3 - 3x + 3 \Rightarrow f'(x) = 3x^2 - 3$

Let $f'(x) = 0 \Rightarrow 3x^2 - 3 = 0$

$$\Rightarrow 3(x-1)(x+1) = 0$$

$$\Rightarrow x = \mp 1, 1 \text{ which are critical point}$$



When $x \in (-\infty, -1) \cup (1, \infty)$

$f'(x) = 3(x-1)(x+1)$ is positive.

When $x \in (-1, 1)$

$f'(x) = 3(x-1)(x+1)$ is negative.

$f'(x)$

From, above number line, we observe that at $x = -1$, $f'(x)$ changes its sign from +ve to -ve as x passes through $x = -1$ and at $x = 1$, $f'(x)$ changes its sign from -ve to +ve as x passes through $x = 1$.

Therefore function attains local maximum value at $x = -1$ and local minimum value at $x = 1$.

Problem-2

Find all points of local maxima and local minima as well as corresponding local maximum and local minimum values for the function $f(x) = (x-1)^3(x+1)^2$

Answer:

Given $f(x) = (x-1)^3(x+1)^2$

Then $f'(x) = 3(x-1)^2(x+1)^2 + 2(x+1)(x-1)^3$

$$\Rightarrow f'(x) = (x-1)^2(x+1)\{3(x+1) + 2(x-1)\}$$

$$\Rightarrow f'(x) = (x-1)^2(x+1)(5x+1)$$

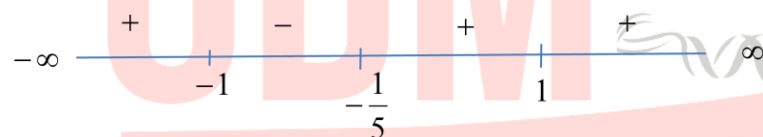

At points of local maxima and local minima, we must have

$$f'(x) = 0 \Rightarrow (x-1)^2(x+1)(5x+1) = 0$$

So, $x = 1$, $x = -1$, $x = -\frac{1}{5}$ *Changing your Tomorrow*

Since $(x-1)^2$ is always positive, therefore the sign of $f'(x)$ is the same as the $(x+1)(5x+1)$

Clearly from number line $f'(x)$ does not change its sign as x passes through 1. so $x = 1$ neither a point of local maximum nor a point of the local minimum. $x = 1$ is the point of inflection. But $x = -1$ the function has local maximum value. And at $x = -\frac{1}{5}$ function attains local maximum value.

Hence, local maximum value is $f(-1) = 0$ and local minimum value is $f(-\frac{1}{5}) = -\frac{3456}{3125}$

Points Of Inflection

For the function $y = f(x)$ to have maximum or minimum value at $x = a$, $\frac{dy}{dx} = 0$ at $x = a$. But if $\frac{dy}{dx} = 0$ at $x = a$, it is not essential that the function may have maximum or minimum values at $x = a$. For it may happen that $\frac{dy}{dx}$ does not change sign from -ve to +ve as +ve to -ve as x passes through value a and consequently, function may go on increasing or decreasing.

Thus the condition that $\frac{dy}{dx} = 0$ for a maximum or a minimum value of the function $y = f(x)$ is only necessary and not sufficient.

DEFINITION

A point on the curve $y = f(x)$ at which $\frac{dy}{dx} = 0$ but $\frac{dy}{dx}$ does not change sign as x passes through the point is called a point of inflexion.

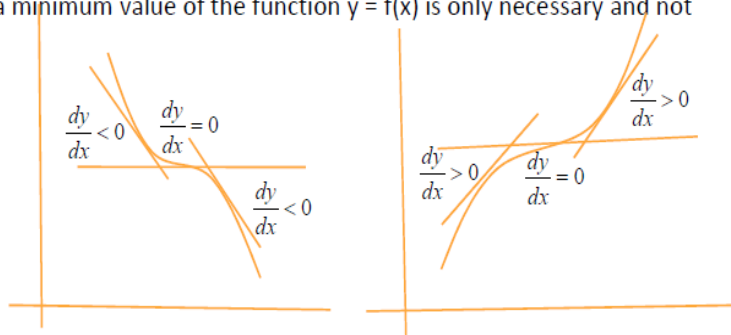

Problem-3

Find the point of inflexion of the function $f(x) = x^5$

Answer:

Given $f(x) = x^5$

Then $\frac{dy}{dx} = 5x^4$

For critical point

$\frac{dy}{dx} = 0 \Rightarrow 5x^4 = 0 \Rightarrow x = 0$

Now, when $x = 0^-$

$\frac{dy}{dx} = 5x^4$ is positive.

When $x = 0^+$

$\frac{dy}{dx} = 5x^4$ is positive.

Here $\frac{dy}{dx}$ does not change its sign. Hence function has point of inflexion at $x = 0$

Second Derivative Test Of Maxima

As proved in the first derivative test, $f(x)$ has the maximum value at $x = a$ if $\frac{dy}{dx}$ changes sign from +ve to -ve at $x = a$.

$\frac{dy}{dx}$

But $\frac{dy}{dx}$ is itself a function of x . Since it changes sign from +ve to -ve. Therefore, it decreases at $x = a$ and hence its

derivative $\frac{d\left(\frac{dy}{dx}\right)}{dx} = \frac{d^2y}{dx^2}$ is -ve at $x = a$.

Hence the function $y = f(x)$ has maximum value at $x = a$ if

$$(i) \frac{dy}{dx} = 0, x = a$$

$$(ii) \frac{d^2y}{dx^2} \text{ is -ve at } x = a$$

Second Derivative Test Of Minima

As proved in the first derivative test, $f(x)$ has minimum value at $x = a$ if $\frac{dy}{dx}$ changes sign from -ve to +ve at $x = a$.

But $\frac{dy}{dx}$ is itself a function of x . Since it changes sign from -ve to +ve. Therefore, it increases at $x = a$ and hence its

derivative $\frac{d\left(\frac{dy}{dx}\right)}{dx} = \frac{d^2y}{dx^2}$ is +ve at $x = a$.

Hence the function $y = f(x)$ has minimum value at $x = a$ if

$$(i) \frac{dy}{dx} = 0, x = a$$

$$(ii) \frac{d^2y}{dx^2} \text{ is +ve at } x = a$$

NOTE:

If $\frac{d^2y}{dx^2} = 0$ at $x = a$, then the function may have point of inflexion, If $\frac{d^3y}{dx^3} \neq 0$ at $x = a$, then

The function has a point of inflection.

Problems

Problem-1

Determine the maximum and minimum value of the function $y = x^5 - 5x^4 + 5x^3 - 1$

Answer:

Given $y = x^5 - 5x^4 + 5x^3 - 1$

$$\frac{dy}{dx} = 5x^4 - 20x^3 + 15x^2$$

$$\Rightarrow \frac{dy}{dx} = 5x^2(x^2 - 4x + 3) \Rightarrow \frac{dy}{dx} = 5x^2(x^2 - 3x - x + 3)$$

$$\Rightarrow \frac{dy}{dx} = 5x^2(x-1)(x-3)$$

For critical point let $\frac{dy}{dx} = 0 \Rightarrow \frac{dy}{dx} = 5x^2(x-1)(x-3) = 0$ hence, $x = 0, 1, 3$

Now $\frac{d^2y}{dx^2} = 20x^3 - 60x^2 + 30x$

At $x = 0$, $\frac{d^2y}{dx^2} = 20 \times 0 - 60 \times 0 + 30 \times 0 = 0$, so function has neither maximum nor minimum value

at $x = 0$

At $x = 1$, $\frac{d^2y}{dx^2} = 20 \times 1 - 60 \times 1 + 30 \times 1 = -10 < 0$, hence function has maximum value. Maximum value is $f(1) = 0$

At $x = 3$, $\frac{d^2y}{dx^2} = 20 \times 81 - 60 \times 9 + 30 \times 3 = 1620 - 540 + 90 = 1170 > 0$, hence function has minimum value,

Minimum value is $f(3) = -118$.

Problem-2

Determine the local maxima and minima value of the function $y = \sin x + \cos x$ $0 < x < \frac{\pi}{2}$

Answer:

Given $y = \sin x + \cos x$ $0 < x < \frac{\pi}{2}$

$$\Rightarrow \frac{dy}{dx} = \cos x - \sin x$$

For critical point let

$$\Rightarrow \frac{dy}{dx} = 0 \Rightarrow \cos x - \sin x = 0$$

$$\Rightarrow \tan x = 1 = \tan \frac{\pi}{4}$$

$$\Rightarrow x = n\pi + \frac{\pi}{4}$$

$$\text{When } n = 0 \Rightarrow x = \frac{\pi}{4}$$

$$\text{Now, } \frac{d^2y}{dx^2} = -\sin x - \cos x$$

$$\text{At } x = \frac{\pi}{4}, \frac{d^2y}{dx^2} = -\sin \frac{\pi}{4} - \cos \frac{\pi}{4} = -\frac{1}{\sqrt{2}} - \frac{1}{\sqrt{2}} = -\frac{2}{\sqrt{2}} = -\sqrt{2} < 0$$

Hence function attains maximum value.

$$\text{So, the maximum value is } \sin \frac{\pi}{4} - \cos \frac{\pi}{4} = \frac{1}{\sqrt{2}} - \frac{1}{\sqrt{2}} = 0$$

Maximum and Minimum value of a function in closed interval. (Absolute Maxima and Absolute Minima)

Let $y = f(x)$ be a function defined on $[a, b]$. By local maximum (or local minimum) value of the function at a point $c \in [a, b]$ we mean the greatest or least value in the immediate neighborhood of $x = c$. It does not mean greatest or maximum (or the least or the minimum) of $f(x)$ in the interval $[a, b]$. A function may have a number of local maximum or local minimum in a given interval even a local minimum may be greater than local maximum.

Thus, a local maximum value may not be greatest (the maximum) value and local minimum value may not be the least (the minimum) value of the function in any given interval as shown in figure.

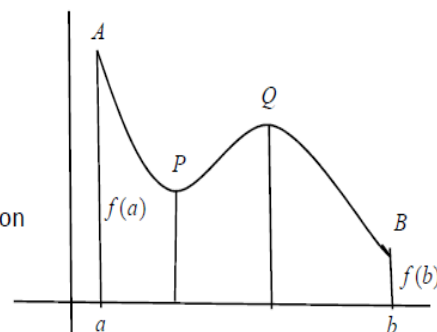

Working rules to find out Absolute Maxima and Absolute Minima.

We may use the following working rules for finding out the maximum (absolute maximum) and the minimum (absolute minimum) of a function f defined on the closed interval $[a, b]$.

STEP-1

$$\text{Find } f'(x) = \frac{dy}{dx}.$$

STEP-2

$$f'(x) = 0. \quad c_1, c_2, \dots, c_n$$

Take $f'(x) = 0$ and find all values of x , let a, c_1, c_2, \dots, c_n be the values of x .

STEP-3

Take the maximum and minimum values out of the values $f(a), f(c_1), f(c_2), \dots, f(c_n), f(b)$

The maximum and minimum values obtained are the absolute maximum or largest value and absolute minimum or smallest value of the function.

Problems

Problem-1

Find the absolute maximum and minimum values of a function $f(x) = 2x^3 - 15x^2 + 36x + 1$ given by on the interval $[1, 5]$

Answer:

We have $f(x) = 2x^3 - 15x^2 + 36x + 1$.

$$\Rightarrow f'(x) = 6x^2 - 30x + 36 = 6(x-3)(x-2)$$

For critical point

$$f'(x) = 0 \Rightarrow x = 2, x = 3$$

We shall now evaluate the value of f at these points and the end points of the interval $[1, 5]$, i.e. at $x = 1, x = 2, x = 3$ and $x = 5$. So

$$f(1) = 2(1^3) - 15(1^2) + 36(1) + 1 = 24$$

$$f(2) = 2(2^3) - 15(2^2) + 36(2) + 1 = 29$$

$$f(3) = 2(3^3) - 15(3^2) + 36(3) + 1 = 28$$

$$f(5) = 2(5^3) - 15(5^2) + 36(5) + 1 = 56$$

Thus, we conclude that the absolute maximum value of f on $[1, 5]$ is 56, occurring at $x = 5$

And the absolute minimum value of f on $[1, 5]$ is 24 which occurs at $x = 1$.

Problem-2

Find the absolute maximum and minimum values of a function f given by

$$f(x) = 12x^{\frac{4}{3}} - 6x^{\frac{1}{3}} \text{ when } x \in [-1, 1]$$

Answer:

We have $f(x) = 12x^{\frac{4}{3}} - 6x^{\frac{1}{3}}$, when $x \in [-1, 1]$

$$\Rightarrow f'(x) = 16x^{\frac{1}{3}} - \frac{2}{x^{\frac{2}{3}}} = \frac{2(8x-1)}{x^{\frac{2}{3}}}$$

For critical point $f'(x) = 0$ gives $x = \frac{1}{8}$

Again $f'(x)$ is not defined at $x = 0$, so, the critical points are $x = 0$ and $x = \frac{1}{8}$

Now evaluating the value of f at critical points $x = 0, x = \frac{1}{8}$ and at the end points of the interval $x = -1, x = 1$

We have

$$f(-1) = 12(-1)^{\frac{4}{3}} - 6(-1)^{\frac{1}{3}} = 18,$$

$$f(0) = 0 - 0 = 0$$

$$f\left(\frac{1}{8}\right) = 12\left(\frac{1}{8}\right)^{\frac{4}{3}} - 6\left(\frac{1}{8}\right)^{\frac{1}{3}} = \frac{-9}{4},$$

$$f(1) = 12(1)^{\frac{4}{3}} - 6(1)^{\frac{1}{3}} = 6$$

Hence we conclude that absolute maximum value of f is 18 that occurs at $x = -1$,

And Absolute minimum value of f is $\frac{-9}{4}$ that occurs at $x = \frac{1}{8}$

Word Problems relating to maxima and minima (plane curve)

Problem-1

Find two numbers whose sum is 24 and whose product is as large as possible.

Answer :

Let two numbers x and y .

$$\text{A.T.Q. } x + y = 24 \text{ or } y = 24 - x \text{ -----(1)}$$

Let P be the product of two numbers

$$\text{So, } P = xy \Rightarrow P = x(24 - x) = 24x - x^2$$

Differentiating w. r. t. x we get

$$\Rightarrow \frac{dP}{dx} = 24 - 2x$$

For critical point

$$\Rightarrow \frac{dP}{dx} = 0 \Rightarrow 24 - 2x = 0 \Rightarrow x = 12$$

Now

$$\frac{d^2P}{dx^2} = -2$$

$$\Rightarrow \left. \frac{d^2P}{dx^2} \right]_{at \ x=12} = -2 < 0$$

, hence P attains maximum value at x = 12 therefore y = 12.

Problem-2

Show that all rectangles inscribed in a given fixed circle, the square has maximum area.

Answer :

Let ABCD be a rectangle inscribed in a given circle with centre O and radius a.

Let AB = 2x and BC = 2y. Applying Pythagoras theorem in triangle OAM,

$$\text{We obtain } OA^2 = AM^2 + OM^2 \Rightarrow a^2 = x^2 + y^2 \Rightarrow y = \sqrt{a^2 - x^2} \dots\dots\dots(1)$$

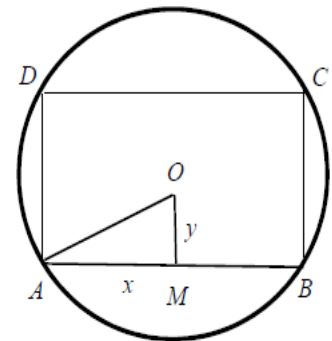

Let A be the area of the rectangle ABCD. Then,

$$A = 4xy = 4x\sqrt{a^2 - x^2} \text{ from equation (1)}$$

$$\Rightarrow A^2 = 16x^2(a^2 - x^2) = 16a^2x^2 - 16x^4$$

$$\Rightarrow \frac{d(A^2)}{dx} = 32a^2x - 64x^3 \dots\dots\dots(2)$$

For critical point

$$\Rightarrow \frac{d(A^2)}{dx} = 0 \Rightarrow 32a^2x - 64x^3 = 0 \Rightarrow x = 0, x = \pm \frac{a}{\sqrt{2}}$$

But $x = 0, x = -\frac{a}{\sqrt{2}}$ are not possible.

$$\therefore x = \frac{a}{\sqrt{2}}$$

From equation (2) we get

$$\frac{d^2(A^2)}{dx^2} = 32a^2 - 192x^2$$

$$\Rightarrow \left. \frac{d^2(A^2)}{dx^2} \right]_{\text{at } x = \frac{a}{\sqrt{2}}} = 32a^2 - 192 \frac{a^2}{2}$$

$$\Rightarrow \left. \frac{d^2(A^2)}{dx^2} \right]_{\text{at } x = \frac{a}{\sqrt{2}}} = -64a^2 < 0$$

Hence, Area attains maximum value at $x = \frac{a}{\sqrt{2}}$

When $x = \frac{a}{\sqrt{2}} \Rightarrow y = \frac{a}{\sqrt{2}}$ from equation (1)

So, $AB = BC$, Hence ABCD is a square

Problem-3

An Apache helicopter of the enemy is flying along the curve given by $y = x^2 + 7$. A soldier, placed at $(3, 7)$ wants to shoot down the helicopter when it is nearest to him. Find the nearest distance.

Answer:

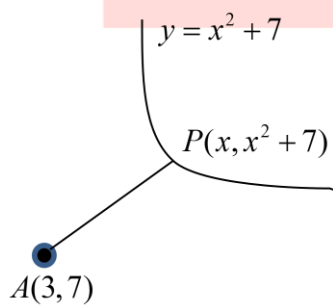

Given curve $y = x^2 + 7$ -----(1)

Let point $P(x, y)$ on the curve is the position of the helicopter, and point $A(3, 7)$ is the position of the soldier.

Now, $P(x, x^2 + 7)$ from equation (1)

Let $D = AB$ is the nearest distance.

$$\Rightarrow D^2 = AB^2 \Rightarrow D^2 = (x-3)^2 + (x^2+7-7)^2 \Rightarrow D^2 = x^4 + x^2 - 6x + 9$$

Differentiating w. r. t. x we get.

$$\Rightarrow \frac{d(D^2)}{dx} = 4x^3 + 2x - 6 = 2(2x^3 + x - 3) \text{ ----- (2)}$$

$$\Rightarrow \frac{d(D^2)}{dx} = 2(x-1)(2x^2 + 2x + 2)$$

For critical point $\frac{d(D^2)}{dx} = 0 \Rightarrow 2(x-1)(2x^2 + 2x + 2) = 0 \Rightarrow x = 1$

Now $\Rightarrow \frac{d^2(D^2)}{dx^2} = 12x^2 + 2$ from equation (2), Therefore $\Rightarrow \left. \frac{d^2(D^2)}{dx^2} \right|_{\text{at } x=1} = 12 \times (1)^2 + 2 = 14 > 0$

Hence, Distance D attains the minimum value at $x = 1$

So point P coordinate is $(1, 8)$

So, the nearest Distance $AB = \sqrt{(3-1)^2 + (7-8)^2} = \sqrt{5}$

Problem-4

A window is in the form of a rectangle surmounted by a semicircular opening. The total perimeter of the window is 10cm. Find the dimension of the window to admit maximum light through the whole opening.

Changing your Tomorrow

Answer:

Let ABCD be a rectangle and a semi-circle is drawn with CD as diameter.

AB = 2x m, CD = 2y m.

$$\therefore 2x + 4y + \pi x = 10 \Rightarrow 4y = 10 - 2x - \pi x \text{-----(1)}$$

$$\Rightarrow A = 4xy + \frac{\pi x^2}{2} \Rightarrow A = x(10 - 2x - \pi x) + \frac{\pi x^2}{2}$$

$$\Rightarrow A = (10x - 2x^2 - \pi x^2) + \frac{\pi x^2}{2} \Rightarrow A = 10x - 2x^2 - \frac{\pi x^2}{2}$$

$$\Rightarrow \frac{dA}{dx} = 10 - 4x - \pi x \quad \text{and} \quad \frac{d^2A}{dx^2} = -4 - \pi$$

For maximum or minimum

$$\frac{dA}{dx} = 0 \Rightarrow 10 - 4x - \pi x = 0 \Rightarrow x = \frac{10}{\pi + 4}$$

Hence, $\left. \frac{d^2A}{dx^2} \right|_{\text{at } x = \frac{10}{\pi+4}} = -4 - \pi < 0$ so, Area is maximum.

Putting $x = \frac{10}{\pi + 4}$ in equation (1) we get $y = \frac{5}{\pi + 4}$

So, dimension of the figure $2x = \frac{20}{\pi + 4} \text{ m}$ and $2y = \frac{10}{\pi + 4} \text{ m}$

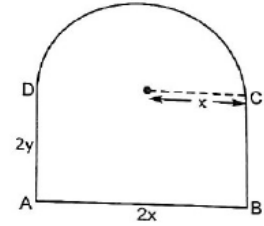

Problem-5

SOLUTION Let AB = 2a, AC = x and CB = y. Since AB is a diameter of the circle having centre

O and C is a point on the semi-circle ACB. Therefore, $\angle ACB = \frac{\pi}{2}$.

Applying Pythagoras theorem in ΔACB , we obtain

$$AB^2 = AC^2 + CB^2$$

$$\Rightarrow (2a)^2 = x^2 + y^2$$

$$\Rightarrow y = \sqrt{4a^2 - x^2} \quad \dots(i)$$

Let A be the area of ΔACB . Then

$$A = \frac{1}{2} AC \times CB = \frac{1}{2} xy \Rightarrow A = \frac{1}{2} x \sqrt{4a^2 - x^2}$$

$$\Rightarrow \frac{dA}{dx} = \frac{1}{2} \left\{ \sqrt{4a^2 - x^2} - \frac{x^2}{\sqrt{4a^2 - x^2}} \right\} = \frac{2a^2 - x^2}{\sqrt{4a^2 - x^2}}$$

The stationary values of A are given by $\frac{dA}{dx} = 0$.

$$\therefore \frac{dA}{dx} = 0$$

$$\Rightarrow \frac{2a^2 - x^2}{\sqrt{4a^2 - x^2}} = 0 \Rightarrow 2a^2 = x^2 \Rightarrow x = \sqrt{2}a$$

Now, $\frac{dA}{dx} = \frac{2a^2 - x^2}{\sqrt{4a^2 - x^2}}$

$$\Rightarrow \frac{d^2A}{dx^2} = \frac{\sqrt{4a^2 - x^2} \times -2x - (2a^2 - x^2) \times \frac{-x}{\sqrt{4a^2 - x^2}}}{(\sqrt{4a^2 - x^2})^2} = -\frac{x(6a^2 - x^2)}{(4a^2 - x^2)^{3/2}}$$

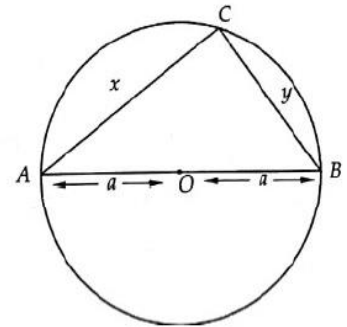

$$\therefore \left(\frac{d^2 A}{dx^2} \right)_{x=\sqrt{2}a} = -2 < 0$$

Thus, A is maximum when $x = \sqrt{2}a$ and $y = \sqrt{2}a$.

Hence, the area of $\triangle ABC$ is maximum when it is isosceles.

Word Problems relating to maxima and minima (solid figures)

Problem-1

A square piece of tin of side 24 cm is to be made into a box without top by cutting a square from each corner and folding up the flaps to form a box. What should be the side of the square to be cut off so that the volume of the box is maximum? Also, find this maximum volume.

SOLUTION Let x cm be the length of a side of the square which is cut-off from each corner of the plate. Then, dimensions of the box as shown in Fig. 18.41 are Length = $24 - 2x$, Breadth = $24 - 2x$ and height = x .

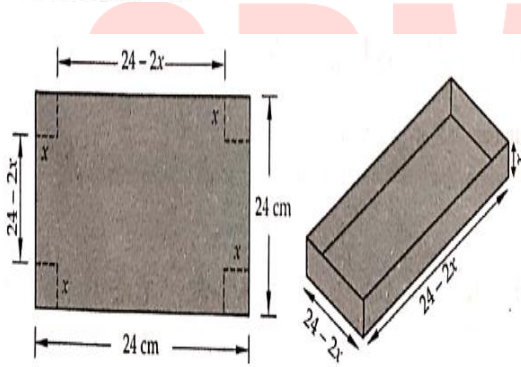

Let V be the volume of the box. Then,

$$V = (24 - 2x)^2 x = 4x^3 - 96x^2 + 576x$$

$$\Rightarrow \frac{dV}{dx} = 12x^2 - 192x + 576 \quad \text{and} \quad \frac{d^2V}{dx^2} = 24x - 192$$

The critical numbers of V are given by $\frac{dV}{dx} = 0$.

$$\therefore \frac{dV}{dx} = 0$$

$$\Rightarrow 12x^2 - 192x + 576 = 0 \Rightarrow x^2 - 16x + 48 = 0 \Rightarrow (x - 12)(x - 4) = 0 \Rightarrow x = 12, 4$$

But, $x = 12$ is not possible. Therefore, $x = 4$.

Clearly, $\left(\frac{d^2V}{dx^2} \right)_{x=4} = 24 \times 4 - 192 < 0$. Thus, V is maximum when $x = 4$.

Hence, the volume of the box is maximum when the side of the square is 4 cm.

Putting $x = 4$ in $V = (24 - 2x)^2 x$, we obtain that the maximum volume of the box is given by $V = (24 - 8)^2 \times 4 = 1024 \text{ cm}^3$.

Problem-2

Find the volume of the largest cylinder that can be inscribed in a sphere of radius r cm.

SOLUTION Let h be the height and R be the radius of the base of the inscribed cylinder. Let V be the volume of the cylinder. Then,

$$V = \pi R^2 h \quad \dots(i)$$

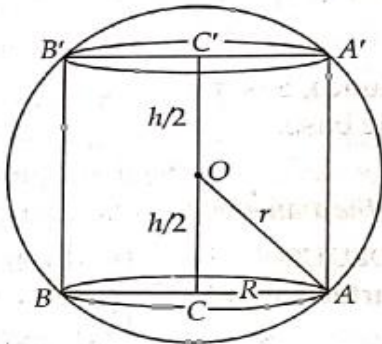

Applying Pythagoras Theorem in ΔOCA , we get

$$\begin{aligned} \therefore OA^2 &= OC^2 + CA^2 \\ \Rightarrow r^2 &= \left(\frac{h}{2}\right)^2 + R^2 \Rightarrow R^2 = r^2 - \frac{h^2}{4} \end{aligned}$$

Substituting the value of R^2 in (i), we get

$$\begin{aligned} V &= \pi \left(r^2 - \frac{h^2}{4} \right) h \\ \Rightarrow V &= \pi r^2 h - \frac{\pi}{4} h^3 \\ \Rightarrow \frac{dV}{dh} &= \pi r^2 - \frac{3\pi h^2}{4} \quad \text{and} \quad \frac{d^2V}{dh^2} = -\frac{3\pi h}{2} \end{aligned}$$

The critical numbers of V are given by $\frac{dV}{dh} = 0$.

$$\therefore \frac{dV}{dh} = 0 \Rightarrow \pi r^2 - \frac{3\pi h^2}{4} = 0 \Rightarrow h^2 = \frac{4r^2}{3} \Rightarrow h = \frac{2}{\sqrt{3}} r$$

Clearly, $\left(\frac{d^2V}{dh^2}\right)_{h=\frac{2r}{\sqrt{3}}} = -\sqrt{3}\pi r < 0$. Thus, V is maximum when $h = \frac{2r}{\sqrt{3}}$.

Putting $h = \frac{2r}{\sqrt{3}}$ in $R^2 = r^2 - \frac{h^2}{4}$, we obtain $R = \sqrt{\frac{2}{3}} r$.

Substituting the values of R^2 and h in (i), we find that the maximum volume of the cylinder is given by

$$V = \pi R^2 h = \pi \left(\frac{2}{3} r^2\right) \left(\frac{2r}{\sqrt{3}}\right) = \frac{4\pi r^3}{3\sqrt{3}}$$

Problem-3

Show that the height of the cylinder of maximum volume that can be inscribed in a sphere of radius a is $\frac{2a}{\sqrt{3}}$.

SOLUTION Let r be the radius of the base and h be the height of the cylinder $ABCD$ which is inscribed in a sphere of radius a . It is obvious that for maximum volume the axis of the cylinder must be along the diameter of the sphere. Let O be the centre of the sphere such that $OL = x$. By symmetry, O is the mid-points of LM . Applying Pythagoras Theorem in $\triangle ALO$, we get

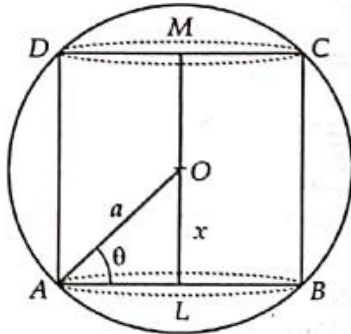

$$\begin{aligned} OA^2 &= OL^2 + AL^2 \\ \Rightarrow a^2 &= x^2 + AL^2 \\ \Rightarrow AL &= \sqrt{a^2 - x^2} \end{aligned}$$

Let V be the volume of the cylinder. Then,

$$\begin{aligned} V &= \pi (AL)^2 \times LM \\ \Rightarrow V &= \pi (AL)^2 \times 2 (OL) \\ \Rightarrow V &= \pi (a^2 - x^2) \times 2x \\ \Rightarrow \frac{dV}{dx} &= 2\pi (a^2 - 3x^2) \text{ and } \frac{d^2V}{dx^2} = -12\pi x \end{aligned}$$

The critical numbers of V are given by $\frac{dV}{dx} = 0$.

$$\therefore \frac{dV}{dx} = 0 \Rightarrow 2\pi (a^2 - 3x^2) = 0 \Rightarrow x = \frac{a}{\sqrt{3}}$$

$$\text{Clearly, } \left(\frac{d^2V}{dx^2} \right)_{x=a/\sqrt{3}} = -12\pi \times \frac{a}{\sqrt{3}} < 0.$$

Hence, V is maximum when $x = \frac{a}{\sqrt{3}}$ and hence $LM = 2x = \frac{2a}{\sqrt{3}}$. In other words, the height of the cylinder of maximum volume is $\frac{2a}{\sqrt{3}}$.

Problem-4

Show that the volume of the largest cone that can be inscribed in a sphere of radius R is $\frac{8}{27}$ of the volume of the sphere.

SOLUTION Let VAB be a cone of greatest volume inscribed in a sphere of radius R . It is obvious that for maximum volume the axis of the cone must be along a diameter of the sphere. Let VC be the axis of the cone and O be the centre of the sphere such that $OC = x$. Then,

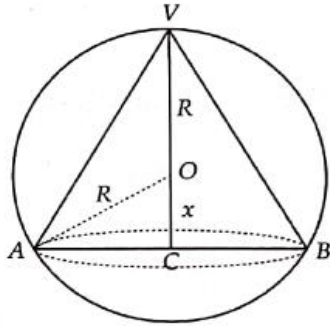

$VC = VO + OC = R + x = \text{height of the cone.}$

Applying Pythagoras Theorem in $\triangle ACO$, we get

$$OA^2 = AC^2 + OC^2$$

$$\Rightarrow AC^2 = OA^2 - OC^2 = R^2 - x^2$$

Let V be the volume of the cone. Then,

$$V = \frac{1}{3} \pi (AC)^2 (VC)$$

$$\Rightarrow V = \frac{1}{3} \pi (R^2 - x^2) (R + x) \quad \dots(i)$$

$$\Rightarrow \frac{dV}{dx} = \frac{1}{3} \pi \left\{ R^2 - x^2 - 2x(R + x) \right\}$$

$$\Rightarrow \frac{dV}{dx} = \frac{1}{3} \pi (R^2 - 2Rx - 3x^2) \quad \text{and} \quad \frac{d^2V}{dx^2} = \frac{1}{3} \pi (-2R - 6x)$$

The critical numbers of V are given by $\frac{dV}{dx} = 0$.

$$\therefore \frac{dV}{dx} = 0$$

$$\Rightarrow R^2 - 2Rx - 3x^2 = 0 \Rightarrow (R - 3x)(R + x) = 0 \Rightarrow R - 3x = 0 \Rightarrow x = \frac{R}{3} \quad [\because R + x \neq 0]$$

Putting $x = \frac{R}{3}$ in $\frac{d^2V}{dx^2} = \frac{1}{3} \pi (-2R - 6x)$, we get

$$\left(\frac{d^2V}{dx^2} \right)_{x=R/3} = -\frac{4}{3} R \pi < 0.$$

Thus, V is maximum when $x = \frac{R}{3}$. Putting $x = \frac{R}{3}$ in (i), we obtain

$$\begin{aligned} V = \text{Maximum volume of the cone} &= \frac{1}{3} \pi \left(R^2 - \frac{R^2}{9} \right) \left(R + \frac{R}{3} \right) = \frac{32 \pi R^3}{81} \\ &= \frac{8}{27} \left(\frac{4}{3} \pi R^3 \right) = \frac{8}{27} (\text{Volume of the sphere}). \end{aligned}$$

Problem-5

Prove that the radius of the right circular cylinder of greatest curved surface which can be inscribed in a given cone is half of that of the cone.

SOLUTION Let VAB be the cone of base radius $r = OA$ and height $h = VO$. Let a cylinder of base radius $OC = x$ and height $= OO'$ be inscribed in the cone.

Clearly, $\Delta VOB \sim \Delta B'DB$

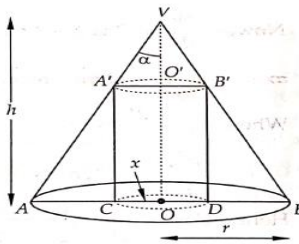

$$\begin{aligned} \therefore \frac{VO}{B'D} &= \frac{OB}{DB} \\ \Rightarrow \frac{h}{B'D} &= \frac{r}{r-x} \\ \Rightarrow B'D &= \frac{h(r-x)}{r} \end{aligned}$$

Let S be the curved surface area of the cylinder. Then,

$$\begin{aligned} S &= 2\pi(OC)(B'D) \\ \Rightarrow S &= 2\pi x \frac{h(r-x)}{r} = \frac{2\pi h}{r}(rx - x^2) \\ \Rightarrow \frac{dS}{dx} &= \frac{2\pi h}{r}(r - 2x) \quad \text{and} \quad \frac{d^2 S}{dx^2} = -\frac{4\pi h}{r} \end{aligned}$$

The critical numbers of S are given by $\frac{dS}{dx} = 0$.

$$\therefore \frac{dS}{dx} = 0 \Rightarrow \frac{2\pi h}{r}(r - 2x) = 0 \Rightarrow x = \frac{r}{2}$$

Clearly, $\frac{d^2 S}{dx^2} = -\frac{4\pi h}{r} < 0$ for all x .

Hence, S is maximum when $x = \frac{r}{2}$ i.e. radius of the cylinder is half of the radius of the cone.