

Chapter-4**MOVING CHARGES AND MAGNETISM****Concept of Magnetic Field**

Just as stationary charges produce an electric field (\vec{E}), moving charges or electric currents produce a magnetic field (\vec{B}) in addition to the electric field and magnetic field produces effect on moving charges or electric current.

Source of Magnetic Field: -

- Current element
- Moving charges

Unit and dimensions

- SI unit of the magnetic field is $\text{NA}^{-1}\text{m}^{-1}$ or tesla (T)

- Dimension: - $B = \frac{F}{qv} = \frac{[M^1L^1T^{-2}]}{[AT][LT^{-1}]} = [M^1L^0T^{-2}A^{-1}]$

Symbols of Magnetic field on the plane of the paper

(a) Magnetic lines of force from N to S



(b) Uniform magnetic field Emerging out

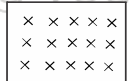

(c) Uniform magnetic field in to

**Biot-Savart Law: -**

According to Biot-Savart law, the magnitude of the field $d\vec{B}$ is

- (a) Directly proportional to the current I through the conductor, $dB \propto I$
- (b) Directly proportional to the length $d\ell$ of the current element, $dB \propto d\ell$
- (c) Directly proportional to $\sin \theta$, $dB \propto \sin \theta$
- (d) Inversely proportional to the square of the distance r of the point P from the current element,

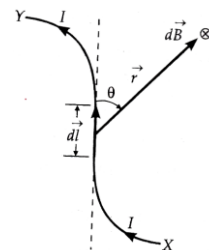

$$dB \propto \frac{1}{r^2}$$

Combining all these four factors, we get

$$dB \propto \frac{Idl \sin \theta}{r^2} \text{ Or } dB = K \cdot \frac{Idl \sin \theta}{r^2}$$

$$dB = \frac{\mu_0}{4\pi} \frac{Idl \sin \theta}{r^2}$$

Vector form of Biot-savart's law

$$\vec{dB} = \frac{\mu_0 I}{4\pi} \frac{d\vec{l} \times \vec{r}}{r^3}$$

Biot- Savart Law vs. Coulomb's Law.

Points of similarity: -

1. Depend inversely on the square of the distance from the source to the point of observation.
2. Long-range field.
3. The principle of superposition is applicable.

Points of difference: -

	Biot-savart's Law	Coulomb's Law
1	The magnetic field is produced by a vector source: the current element $I d\vec{l}$.	The electrostatic field is produced by a scalar source: the electric charge dq .
2	The direction of the magnetic field is perpendicular to the plane containing the displacement vector \vec{r} and the current element $I d\vec{l}$.	The direction of the electrostatic field is along the displacement vector joining the source and the field point.

3 There is angle dependence in Biot-savarts law.

There is no such angle dependence is the Coulomb's law for the electrostatic field.

Question – 01

State the dimensional formula of $\mu_0 \epsilon_0$

We know that $\frac{1}{4\pi\epsilon_0} = 9 \times 10^9 \text{ Nm}^2\text{C}^{-2}$ And $\frac{\mu_0}{4\pi} = 10^{-7} \text{ TmA}^{-1}$

$$\therefore \mu_0 \epsilon_0 = \left(\frac{\mu_0}{4\pi} \right) \left(\frac{4\pi}{1} \right) = 10^{-7} \times \frac{1}{9 \times 10^9} = \frac{1}{(3 \times 10^8)^2}$$

But $3 \times 10^8 \text{ ms}^{-1}$ = speed of light in a vacuum (c)

$$\therefore \mu_0 \epsilon_0 = \frac{1}{c^2} \quad \text{Or } c = \frac{1}{\sqrt{\mu_0 \epsilon_0}}, \text{ the unit of } \mu_0 = \left(\frac{\text{TM}}{\text{A}} \right), \text{ Dimension of } \mu_0 = [M^1 L^1 T^{-2} A^{-2}]$$

Example – 2

A wire placed along the north-south direction carries a current of 8A from south to north. Find the magnetic field due to a 1 cm piece of wire at a point 200 cm northeast from the piece.

Solution: -

Changing your Tomorrow

As the distance OP is much larger than the length of the wire, we can treat the wire as a small current element.

Here $I = 8\text{A}$, $d\ell = 1\text{cm} = 1 \times 10^{-2} \text{ m}$ $r = 200\text{cm} = 2\text{m}$, $\theta = 45^\circ$

$$dB = \frac{\mu_0}{4\pi} \cdot \frac{Id\ell \sin \theta}{r^2} = \frac{8 \times 1 \times 10^{-2} \times \sin 45^\circ}{2^2}$$

$= 1.4 \times 10^{-9} \text{ T}$ The direction of the magnetic field at point P is normally into the plane of the paper.

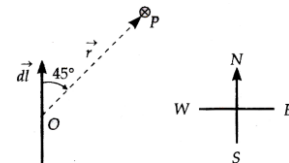

Magnetic field due to a long straight current-carrying conductor: -

Magnetic field due to a long straight current-carrying conductor XY

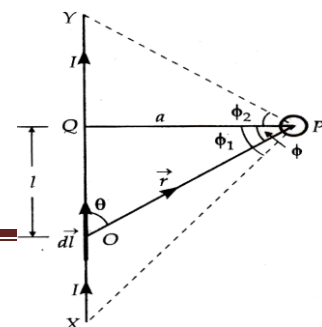

$$B = \frac{\mu_0 I}{4\pi a} [\sin \phi_1 + \sin \phi_2]$$

Special Cases: -

(a) If the conductor XY is infinitely long and the point P lies near the middle of the conductor, then

$$\phi_1 = \phi_2 = \pi/2$$

$$\therefore B = \frac{\mu_0 I}{4\pi a} [\sin 90^\circ + \sin 90^\circ] \text{ or } B = \frac{\mu_0 I}{2\pi a}$$

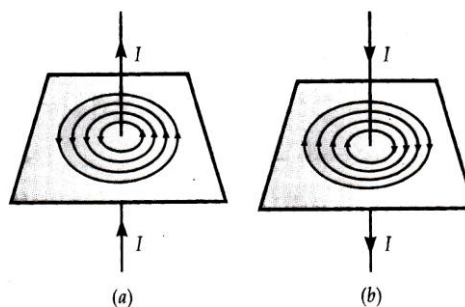

For an infinitely long conductor,

$$B = \frac{\mu_0 I}{2\pi a} \text{ i.e., } B \propto \frac{1}{a}$$

Rules for finding the direction of the magnetic field due to straight current-carrying conductor:-

(a) Right-hand thumb rule

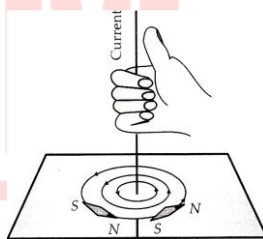

(b) Maxwell's cork screw rule

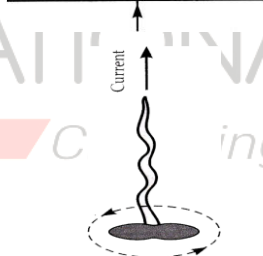

(b) If the conductor XY is infinitely long but the point P lies near the end Y (or X), then

$$\phi_1 = 90^\circ \text{ and } \phi_2 = 0^\circ$$

$$\therefore B = \frac{\mu_0 I}{4\pi a} [\sin 90^\circ + \sin 90^\circ] = \frac{\mu_0 I}{4\pi a}$$

(c) If the conductor is of finite length L and the point P lies on its perpendicular bisector, then

$$\phi_1 = \phi_2 = \phi \text{ and } \sin \phi = \frac{L/2}{\sqrt{a^2 + (L/2)^2}} = \frac{L}{\sqrt{4a^2 + L^2}}$$

$$\therefore B = \frac{\mu_0 I}{4\pi a} [\sin \phi + \sin \phi]$$

$$\frac{\mu_0 I}{4\pi a} \cdot \frac{2L}{\sqrt{4a^2 + L^2}} \text{ or } B = \frac{\mu_0 I L}{2\pi a \sqrt{4a^2 + L^2}}$$

Magnetic Field on the axis of a circular current loop: -

The magnetic field at point P due to the current element is $d\vec{\ell}$

$$dB = \frac{\mu_0}{4\pi} \cdot \frac{I d\ell \sin \theta}{s^2}$$

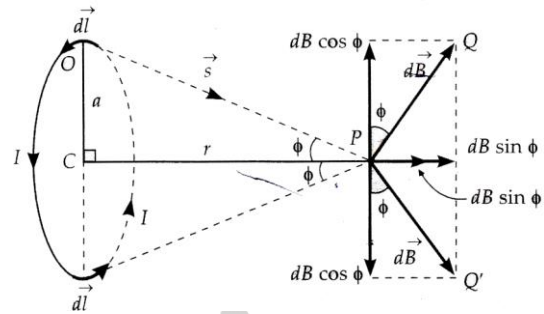

Since $d\vec{\ell} \perp \vec{s}$, i.e., $\theta = 90^\circ$ therefore $dB = \frac{\mu_0}{4\pi} \cdot \frac{I d\ell}{s^2}$

The magnetic field dB can be resolved into two rectangular components $dB \sin \phi$ and $dB \cos \phi$. The components perpendicular to the axis of the loop will be equal and opposite and will cancel out. Their axial components will be in the same direction, so added up.

\therefore The total magnetic field at point P in the direction CP is.

$$B = \int dB \sin \phi$$

$$\text{But } \sin \phi = \frac{a}{s} \text{ and } dB = \frac{\mu_0}{4\pi} \cdot \frac{I d\ell}{s^2}$$

$$\therefore B = \int \frac{\mu_0}{4\pi} \cdot \frac{I d\ell}{s^2} \cdot \frac{a}{s}$$

Since μ_0 and I are constant, and s and a are the same for all points on the circular loop, we have.

$$B = \frac{\mu_0 I a}{4\pi s^3} \int d\ell = \frac{\mu_0 I a}{4\pi s^3} \cdot 2\pi a = \frac{\mu_0 I a^2}{2s^3} \text{ or } B = \frac{\mu_0 I a^2}{2(r^2 + a^2)^{3/2}}$$

As the direction of the field is along +ve X-direction, so we can write $\vec{B} = \frac{\mu_0 I a^2}{2(r^2 + a^2)^{3/2}} \hat{i}$

If the coil consists of N turns, then $B = \frac{\mu_0 N I a^2}{2(r^2 + a^2)^{3/2}}$

The direction of the magnetic field: -

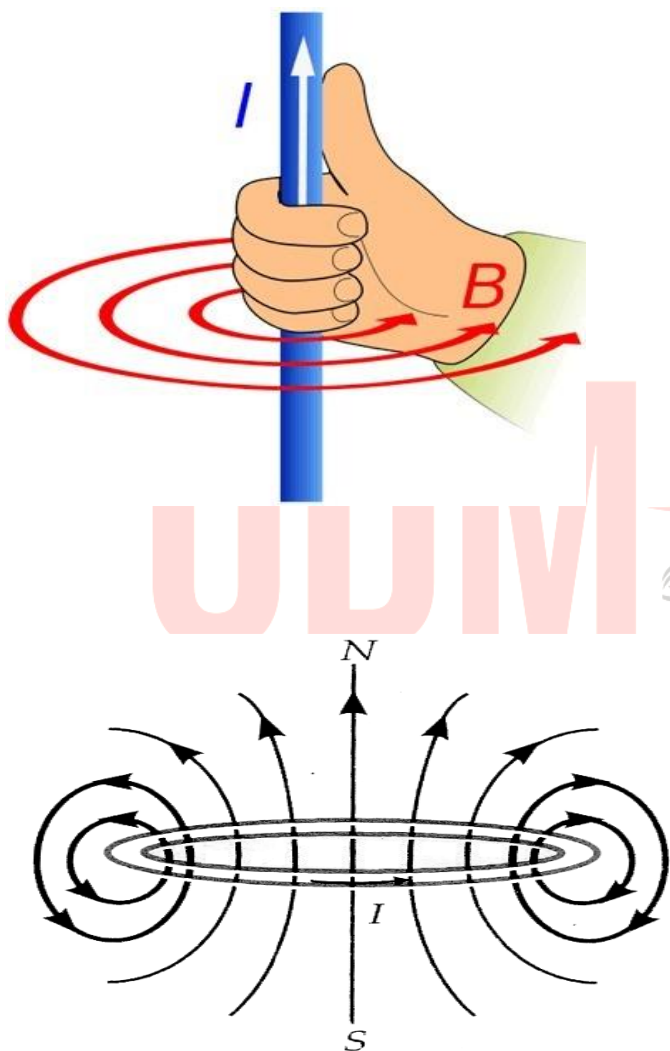

Variation of the magnetic field along the axis of a circular current loop.

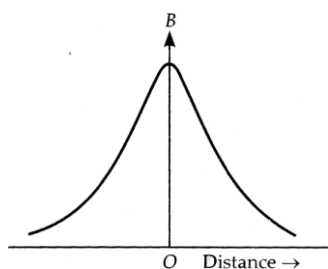

Example: - The plane of a circular coil is horizontal. It has 10 turns each of a radius 8cm. a current of 1A flows through it. The current appears to flow clockwise from a point above the coil. Find the magnitude and direction of the magnetic field at the center of the coil due to the current.

Solution: -

Here $N = 10$, $r = 8 \text{ cm} = 0.08 \text{ m}$, $I = 2 \text{ A}$

$$\therefore B = \frac{\mu_0 NI}{2r} = \frac{4\pi \times 10^{-7} \times 10 \times 2}{2 \times 0.08} = 1.57 \times 10^{-4} \text{ T}$$

As the current flows clockwise when seen from above the coil, the magnetic field at the center of the coil points vertically downwards.

Example:- In the Bohr model of the hydrogen atom, an electron revolves around the nucleus in a circular orbit of radius $5.11 \times 10^{-11} \text{ m}$ at a frequency of $6.8 \times 10^{15} \text{ Hz}$. What is the magnetic field set up at the center of the orbit?

Solution:-

If n is the frequency of revolution of the electron, then

$$I = ne = 6.8 \times 10^{15} \times 1.6 \times 10^{-19}$$

$$= 6.8 \times 1.6 \times 10^{-4} \text{ A}$$

$$\therefore B = \frac{\mu_0 I}{2r}$$

$$= \frac{4\pi \times 10^{-7} \times 6.8 \times 1.6 \times 10^{-4}}{2 \times 5.11 \times 10^{-11}} = 13.4 \text{ T}$$

The magnetic field produced at the center of the nucleus,

$$B = \frac{\mu_0 I}{2r} = \frac{4\pi \times 10^{-7} \times 1.12 \times 10^{-3}}{2 \times 0.5 \times 10^{-10}} = 14.07 \text{ T}$$

Example: -A circular coil, having 100 turns of wire, of the radius (nearly) 20 cm each, lies in the XY plane with its center at the origin of coordinates. Find the magnetic field, at the point

$(0, 0, 20\sqrt{3}\text{cm})$, when this coil carries a current of $\left(\frac{2}{\pi}\right)\text{A}$.

Solution: -

$$N = 100, a = 20\text{cm} = 0.2\text{m}, z = 20\sqrt{3}\text{cm} = 0.2\sqrt{3}\text{m}, I = \frac{2}{\pi}\text{A}$$

The coil lies in XY-plane and the field point $(0, 0, 20\sqrt{3})$ lies on the z-axis

The magnetic field at the axial field point,

$$B = \frac{\mu_0 N I a^2}{2(a^2 + z^2)^{3/2}} = \frac{4\pi \times 10^{-7} \times 100 \times \left(\frac{2}{\pi}\right) \times (0.2)^2}{2\left[(0.2)^2 + (0.2\sqrt{3})^2\right]^{3/2}} \text{T}$$

$$= \frac{4 \times 10^{-5} \times 0.04}{2(0.2)^3 (1+3)^{3/2}} \text{T} = \frac{0.16 \times 10^{-5}}{2 \times 0.008 \times 8} \text{T}$$

$$\frac{1}{8} \times 10^{-4} \text{T} = 25 \times 10^{-6} \text{T} = 25 \mu\text{T}$$

Example:-The magnetic field due to a current-carrying circular loop of radius 12 cm at its center is $0.50 \times 10^{-4} \text{T}$. Find the magnetic field due to this loop at a point on the axis at a distance of 5.0 cm from the centre.

Solution:-

$$B_{\text{centre}} = \frac{\mu_0 I}{2a} \text{ and } B_{\text{axial}} = \frac{\mu_0 I a^2}{2(a^2 + r^2)^{3/2}}$$

$$\therefore \frac{B_{\text{axial}}}{B_{\text{centre}}} = \frac{a^3}{(a^2 + r^2)^{3/2}} \text{ or } B_{\text{axial}} = \frac{a^3}{(a^2 + r^2)^{3/2}} \times B_{\text{centre}}$$

Here $a = 12\text{cm} = 12 \times 10^{-2}\text{m}$, $r = 5\text{cm} = 5 \times 10^{-2}\text{m}$

$$B_{\text{centre}} = 0.50 \times 10^{-4}\text{T}$$

$$\therefore B_{\text{axial}} = \frac{(12 \times 10^{-2})^3}{[144 \times 10^{-4} + 25 \times 10^{-4}]^{3/2}} \times 0.50 \times 10^{-4}\text{T}$$

$$= \frac{(12)^3 \times 0.50 \times 10^{-4}}{169 \times 13} = 3.9 \times 10^{-5}\text{T}$$

Example:- Two identical circular coils of radius 0.1m, each having 20 turns are mounted coaxially 0.1m apart. A current of 0.5A is passed through both of them

(i) in the same direction

(ii) in the opposite directions. Find the magnetic field at the center of each coil.

Solution:-

Here $a = 0.1\text{m}$, $N = 20$, $r = 0.1\text{m}$, $I = 0.5\text{A}$. The magnetic field at the center of each coil due to its own current is

$$B_1 = \frac{\mu_0 NI}{2a} = \frac{4\pi \times 10^{-7} \times 20 \times 0.5}{2 \times 0.1} = 6.28 \times 10^{-5}\text{T}$$

The magnetic field at the center of one coil due to the current in the other coil is

$$B_2 = \frac{\mu_0 NIa^2}{2(a^2 + r^2)^{3/2}}$$

$$= \frac{4\pi \times 10^{-7} \times 20 \times 0.5 \times (0.1)^2}{2[(0.1)^2 + (0.1)^2]^{3/2}} = \frac{0.628 \times 10^{-7}}{[2 \times (0.1)^2]^{3/2}}$$

$$= \frac{0.628 \times 10^{-7}}{2\sqrt{2} \times 10^{-3}} = 2.22 \times 10^{-5}\text{T}$$

(i) When the currents are in the same direction, the resultant field at the center of each coil is

$$B = B_1 + B_2 = 6.28 \times 10^{-5} + 2.22 \times 10^{-5} = 8.50 \times 10^{-5} \text{ T}$$

(ii) When the currents are in opposite directions, the resultant field is

$$B = B_1 - B_2 = 6.28 \times 10^{-5} - 2.22 \times 10^{-5} = 4.06 \times 10^{-5} \text{ T}$$

Example: -Two coaxial circular loops L_1 and L_2 of radii 3 cm and 4 cm are placed as shown. What should be the magnitude and direction of the current in the loop L_2 so that the net magnetic field at the point O be zero?

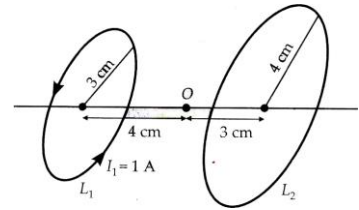

Solution: -

For the net magnetic field at point O to be zero, the direction of current in loop L_2 should be opposite to that in loop L_1 .

The magnitude of the magnetic field due to current I_1 in L_1 = Magnitude of the magnetic field due to current I_2 in L_2

$$\text{or } \frac{\mu_0 I_1 (0.03)^2}{2[(0.03)^2 + (0.04)^2]^{3/2}} = \frac{\mu_0 I_2 (0.04)^2}{2[(0.04)^2 + (0.03)^2]^{3/2}}$$

$$I_2 = \frac{(0.03)^2}{(0.04)^2} I_1$$

$$= \frac{9}{16} \times 1 \text{ A} = 0.56 \text{ A}$$

Example: -A long wire having a semi-circular loop of radius r carries a current I , as shown in the figure. Find the magnetic field due to the entire wire at point O.

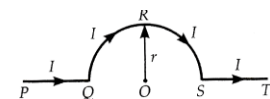

Solution: -

Magnetic field due to linear portion. Any element $d\vec{\ell}$ of linear portions like PQ or ST will make angles 0 or π with the position vector \vec{r} . Therefore, the field at O due to the linear portion is.

$$B = \frac{\mu_0}{4\pi} \cdot \frac{Idl \sin \theta}{r^2} = 0$$

Magnetic field due to the semi-circular portion. Any element $d\vec{\ell}$ on this portion will be perpendicular to the position vector \vec{r} , therefore, field due to one such element at the point will be.

$$dB = \frac{\mu_0}{4\pi} \cdot \frac{Idl \sin \pi/2}{r^2} = \frac{\mu_0}{4\pi} \frac{Idl}{r^2}$$

The magnetic field due to the entire circular portion is given by.

$$B = \int dB = \frac{\mu_0 I}{4\pi r^2} \int d\ell = \frac{\mu_0 I}{4\pi r^2} \cdot \pi r = \frac{\mu_0 I}{4r}$$

\therefore The total magnetic field at point O = $\frac{\mu_0 I}{4r}$

Example: -A straight wire carrying a current of 12A is bent into a semi-circular arc of radius 2.0 cm as shown in figure (a) What is the direction and magnitude of \vec{B} at the center of the arc?

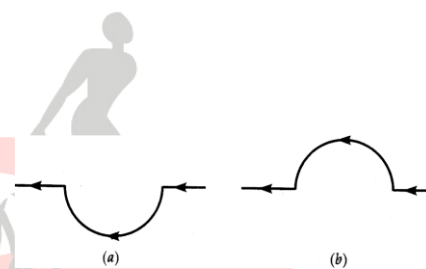

Would your answer change if the wire were bent into a semi-circular arc of the same radius but in the opposite way as shown in the figure.

Solution: -

(a) The magnetic field at the center of the arc is

$$B = \frac{\mu_0 I}{4r} \quad \text{Here } I = 12\text{A}, r = 2.0\text{cm} = 0.02\text{m}, \mu_0 = 4\pi \times 10^{-7} \text{TmA}^{-1}$$

$$\therefore B = \frac{4\pi \times 10^{-7} \times 12}{4 \times 0.02} = 1.9 \times 10^{-4} \text{T}$$

According to the right-hand rule, the direction of the field is normally into the plane of the paper.

(b) The magnetic field will be of the same magnitude,

$$B = 1.9 \times 10^{-4} \text{T}$$

The direction of the field is normally out of the plane of the paper.

Example: -A long wire is bent as shown in the figure. What will be the magnitude and direction of the field at the center O of the circular portion, if a current I is passed through the wire? Assume that the various portions of the wire do not touch at point P.

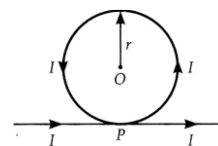

Solution: -

The system consists of a straight conductor and a circular loop. Field due to straight conductor at point O is

$$B_1 = \frac{\mu_0 I}{2\pi r}, \text{ up the plane of the paper}$$

Field due to circular loop at point O is

$$B_2 = \frac{\mu_0 I}{2r}, \text{ up the plane of the paper}$$

\therefore The total field at O is

$$B = B_1 + B_2 = \frac{\mu_0 I}{2r} \left(1 + \frac{1}{\pi} \right) \text{ up the plane of the paper.}$$

Example: -Figure shows a current loop having two circular segments and joined by two radial lines. Find the magnetic field at the centre O.

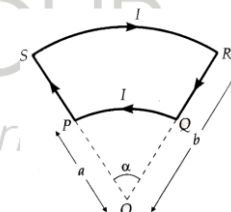

Solution: -

Since the point O lies on lines SP and QR, so the magnetic field at O due to these straight portions is zero.

The magnetic field at O due to the circular segment PQ is

$$B_1 = \frac{\mu_0}{4\pi} \frac{I}{a^2} \ell \quad \text{Here, } \ell = \text{length of the arc PQ} = \alpha a$$

$$\therefore B_1 = \frac{\mu_0}{4\pi} \frac{I\alpha}{a}, \text{ directed normally upward}$$

Similarly, the magnetic field at O due to the circular segment SR is.

$$B_2 = \frac{\mu_0}{4\pi} \cdot \frac{I\alpha}{b}, \text{ directed normally downward.}$$

The resultant field at O is

$$B = B_1 - B_2 = \frac{\mu_0 I \alpha}{4\pi} \left[\frac{1}{a} - \frac{1}{b} \right] \text{ or } B = \frac{\mu_0 I \alpha (b-a)}{4\pi ab}$$

Example:-The wire shown in figure carries a current of 10A. Determine the magnitude of the magnetic field at the center O. Give radius of the bent coil is 3 cm

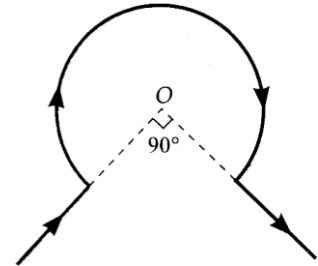

Solution:-As $\theta(\text{rad}) = \frac{\text{Arc}}{\text{Radius}} \quad \therefore \frac{3\pi}{2} = \frac{\ell}{r} \text{ or } \ell = \frac{3\pi r}{2}$

According to Biot-Savart law, the magnetic field at the center O is

$$B = \frac{\mu_0 I \ell}{4\pi r^2} = \frac{\mu_0}{4\pi} \cdot \frac{I}{r^2} \cdot \frac{3\pi r}{2} = \frac{\mu_0}{4\pi} \cdot \frac{3}{2} \cdot \frac{\pi I}{r}$$

$$= \frac{4\pi \times 10^{-7}}{4\pi} \cdot \frac{3}{2} \cdot \frac{22}{7} \times \frac{10}{3 \times 10^{-2}} = 1.57 \times 10^{-3} \text{ T}$$

Example:-In figure abcd is a circular coil of the non-insulated thin uniform conductor. Conductors pa and qc are very long straight parallel conductors tangential to the coil at the points a and c. If a current of 5 A enters the coil from P to a, find the magnetic induction at O, the center of the coil. The diameter of the coil is 10cm.

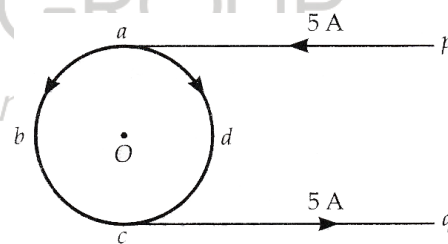

Solution:-Here, $I_{abc} = I_{adc} = 2.5 \text{ A}$, $r = Oa, Ob = Oc = Od = 5 \text{ cm} = 5 \times 10^{-2} \text{ m}$

The magnetic induction at O due to the current in part oabc of the coil is equal and opposite to the magnetic induction due to the current in part adc. So magnetic induction at O due to the coil is zero. Magnetic induction at O due to the straight conductor pa (half infinite segment) is.

$$B_1 = \frac{1}{2} \frac{\mu_0 I}{2\pi r} = \frac{4\pi \times 10^{-7} \times 5}{4\pi \times 5 \times 10^{-2}} = 10^{-5} \text{ T, Normally out of the plane of the paper,}$$

Similarly, magnetic induction at o due to straight conductor qc is

$$B_2 = \frac{\mu_0 I}{4\pi r} = 10^{-5} \text{ T}$$

Normally out of the plane of the paper. Total magnetic induction at o is

$$B = B_1 + B_2 = 10^{-5} + 10^{-5} = 2 \times 10^{-5} \text{ T}$$

Normally out of the plane of the paper.

Example:-The current –loop PQRSTP formed by two circular segments of radii R_1 and R_2 carries a current of I ampere. Find the magnetic field at the common center O. What will be the field if angle $\alpha = 90^\circ$?

Solution:-

The magnetic field at O due to each of the straight parts PQ and RS is zero

because $\theta = 0^\circ$ for each of them.

The magnetic field at the center O due to circular segment QR of radius R_2 is

$$B_1 = \frac{\mu_0}{4\pi} \cdot \frac{I}{R_2^2} \ell_2$$

Here, $\ell_2 =$ length of the circular segment $QR = \alpha R_2$

$$\therefore B_1 = \frac{\mu_0}{4\pi} \cdot \frac{I\alpha}{R_2}, \text{ directed normally downward}$$

Similarly, the magnetic field at O due to the circular segment STP is

$$B_2 = \frac{\mu_0}{4\pi} \frac{I(2\pi - \alpha)}{R_1}, \text{ directed normally downward.}$$

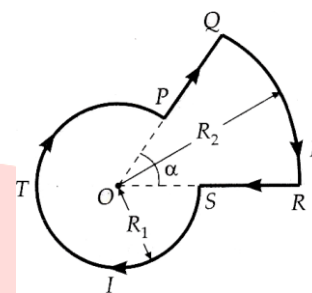

Hence the resultant field at O is $B = B_1 + B_2 = \frac{\mu_0 I}{4\pi} \left(\frac{\alpha}{R_2} + \frac{2\pi - \alpha}{R_1} \right)$, directed normally downward.

If $\alpha = 90^\circ = \pi/2$, then $B = \frac{\mu_0}{4\pi} \left(\frac{\pi}{2R_2} + \frac{3\pi}{2R_1} \right) = \frac{\mu_0 I}{8} \left[\frac{1}{R_2} + \frac{3}{R_1} \right]$

Ampere's Circuital Law: -

This law states that "The line integral of the resultant magnetic field along a closed plane curve is equal to μ_0 time the total current crossing the area bounded by the closed curve provided the electric field inside the loop remains constant"

Thus

The law in integral form $\oint \mathbf{B} \cdot d\mathbf{l} = \mu_0 I$ where μ_0 is the permeability of free space and I is the net current enclosed by the loop

Proof: Consider a long straight conductor carrying current I perpendicular to the page in the upward direction as shown below in the figure

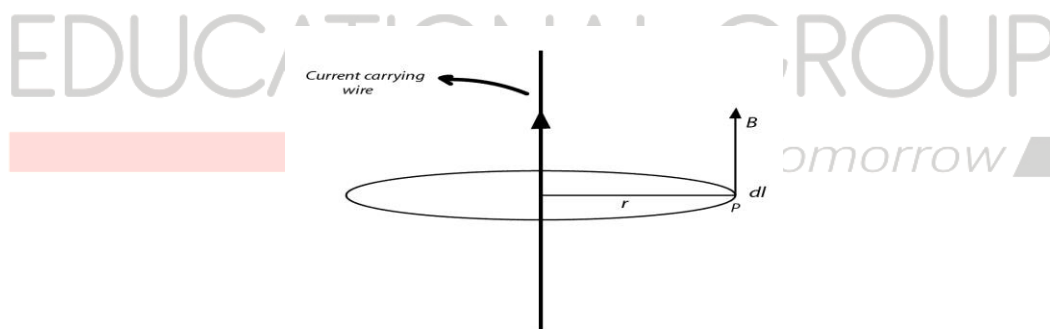

Applying Biot Savart law, the magnetic field at any point P which is at a distance R from the conductor is given by

$$B = \frac{\mu_0 I}{2\pi R}$$

And the field is tangent to the circle at each point. The line integral of B around the circle is

$$\oint \mathbf{B} \cdot d\mathbf{l} = \oint \frac{\mu_0 I}{2\pi R} dl = \frac{\mu_0 I}{2\pi R} \oint dl$$

since $\oint dl = 2\pi R$ ie, the circumference of the circle so,

$$\oint \mathbf{B} \cdot d\mathbf{l} = \mu_0 I$$

A cylindrical conductor with radius R carries a current I. The current is uniformly distributed over the cross-sectional area of the conductor. Find the magnetic field as a function of the distance r from the conductor axis for points both inside ($r < R$) and outside ($r > R$) the conductor.

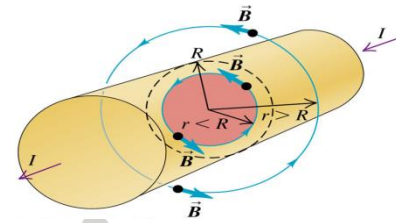

From Ampere's Law, we have:

We will take the ampere loop to be a circle. Hence, for points inside the conductor, the ampere loop will be a circle with radius r, where $r < R$.

$$\oint \mathbf{B} \cdot d\mathbf{l} = \mu_0 I_1 \dots \dots \dots (i)$$

where I_1 is the current passing (piercing) through the surface enclosed by the circular path of radius r. Note that I_1 is the current carried by the cylindrical portion of the conductor having radius 'r' so that

$$I_1 = I(\pi r^2 / \pi R^2) = I r^2 / R^2$$

[The total current I passes through the total cross-section area πR^2 . So the current I_1 passing through the cross-section area πr^2 is $I(\pi r^2 / \pi R^2) = I r^2 / R^2$].

Substituting for I_1 in equation (i) and remembering that the direction of the magnetic field B is along the path of integration everywhere, we have

$$2\pi r B = \mu_0 I r^2 / R^2$$

$$\text{Therefore, } B = \mu_0 I r / 2\pi R^2$$

This shows that the magnetic field at the center of the conductor is zero (since $r = 0$) and it increases linearly with the increase in distance r within the conductor. The maximum value of the field is at the surface of the conductor (corresponding to $r = R$) and is equal to $\mu_0 I / 2\pi R$.

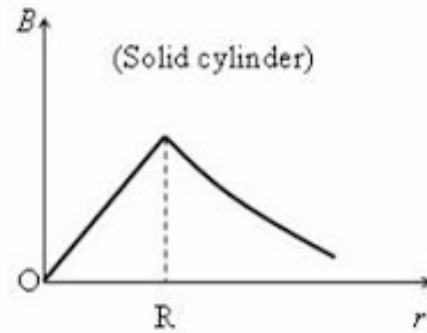

The direction of the field lines is clockwise as we have considered the current to flow *into* the plane of the figure, away from the reader. The magnitude of the magnetic flux density at a point such as P' outside the conductor (at distance $r > R$) is given by

$2\pi r B = \mu_0 I$ since the entire current I passes (pierces) through the surface enclosed by the circular path of radius r .

This gives $B = \mu_0 I / 2\pi r$

[This is the usual expression for the magnetic field due to a long straight (thin) current-carrying conductor].

Problems for Practice:-

01. A wire placed along east-west direction carries a current of 10A from west to east direction. Determine the magnetic field due to a 1.8 cm piece of wire at a point 300 cm north-east from the place.

02. A small current element $I \vec{d\ell}$, with $I \vec{d\ell} = 2\hat{k}$ mm and $I = 2A$ is centred at the origin. Find the magnetic field \vec{dB} at the following points.

- (a) On the x-axis at $x = 3$ m
- (b) On the x-axis at $x = -6$ m
- (c) On the z-axis at $z = 3$ m

03. An element $\Delta\vec{\ell} = \Delta x \hat{i}$ is placed at the origin (as shown in the figure) and carries a current $I = 2A$. Find out the magnetic field at a point P on the y-axis at a distance of 1.0m due to the element $\Delta x = 1\text{cm}$. Give also the direction of the field produced.

The direction of the magnetic field:-

Clearly, the magnitude of the magnetic field will be the same at all points located at the same distance from the conductor. Hence the magnetic lines of force of a straight

The current-carrying conductor is concentric circles with the wire at the center and in a plane perpendicular to the wire. (A line of force is a curve, the tangent to which at any point gives the direction of the magnetic field at that point). If the current flows upwards, the lines of force have an anticlockwise sense and if the current flows downwards then the lines of force have a clockwise sense.

$$B \propto \frac{1}{a}$$

Thus, the graph plotted between the magnetic field B and the distance a from the straight conductor is a hyperbola, as shown in the figure.

Example:- A current of 10A is flowing east to west in a long wire kept horizontally in the east-west direction. Find the magnetic field in a horizontal plane at a distance of

- (a) 10 cm north
 (b) 20 cm south from the wire and in the vertical plane at a distance of
 (c) 40 cm downward and (d) 50 cm upward

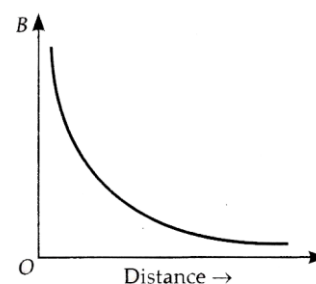

Solution:-

(a) The magnetic field in a horizontal plane at 10 cm north of the wire is

$$B_N = \frac{\mu_0 I}{2\pi r} = \frac{4\pi \times 10^{-7} \times 10}{2\pi \times 0.10} = 2 \times 10^{-5} \text{ T}$$

According to the right-hand thumb rule, the direction of the magnetic field will be downward in the vertical plane

(b) The magnetic field at 20 cm south of the wire is

$$B_S = \frac{4\pi \times 10^{-7} \times 10}{2\pi \times 0.20} = 1 \times 10^{-5} \text{ T}$$

The magnetic field will point upward in the vertical plane.

(c) The magnetic field 40 cm just down the wire is

$$B_D = \frac{4\pi \times 10^{-7} \times 10}{2\pi \times 0.40} = 5 \times 10^{-6} \text{ T}$$

The magnetic field will point south in a horizontal plane.

(d) The magnetic field 50 cm just above the wire is

$$B_U = \frac{4\pi \times 10^{-7} \times 10}{2\pi \times 0.50} = 4 \times 10^{-6} \text{ T}$$

The magnetic field will point north in a horizontal plane.

Example:- A long straight wire carrying a current of 30 A is placed in an external uniform magnetic field of $4.0 \times 10^{-4} \text{ T}$ parallel to the current. Find the magnitude of the resultant magnetic field at a point 2.0 cm away from the wire.

Solution:-

Here $I = 30 \text{ A}$, $r = 2.0 \text{ cm} = 2.0 \times 10^{-2} \text{ m}$

Field due to straight current-carrying wire is

$$B_1 = \frac{\mu_0 I}{2\pi r} = \frac{4\pi \times 10^{-7} \times 30}{2\pi \times 2.0 \times 10^{-2}} = 3.0 \times 10^{-4} \text{ T}$$

This field will act perpendicular to the external field $B_2 = 4.0 \times 10^{-4} \text{ T}$. Hence the magnitude of the resultant field is

$$B = \sqrt{B_1^2 + B_2^2} = \sqrt{(3 \times 10^{-4})^2 + (4.0 \times 10^{-4})^2} = 5 \times 10^{-4} \text{ T}$$

Example:- Figure shows two current-carrying wires 1 and 2. Find the magnitude and directions of the magnetic field at points P, Q, and R.

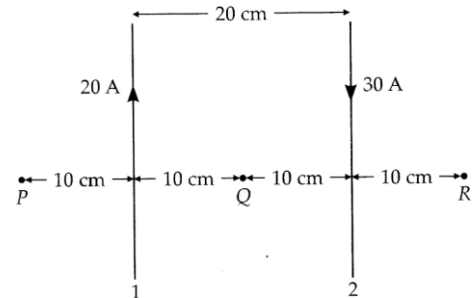

Solution:-

(a) According to right-hand grip rule, the field B_1 of wire 1 at point P will point normally outward while the field B_2 of wire 2 will point normally inward, hence

$$B_p = B_1 - B_2 = \frac{\mu_0 I_1}{2\pi r_1} - \frac{\mu_0 I_2}{2\pi r_2}$$

$$= \frac{4\pi \times 10^{-7}}{2\pi} \left[\frac{20}{0.10} - \frac{30}{0.30} \right] = 2 \times 10^{-5} \text{ T, pointing normally outward.}$$

(b) At point Q, both B_1 and B_2 will point normally inward,

$$\therefore B_Q = B_1 + B_2 = \frac{4\pi \times 10^{-7}}{2\pi} \left[\frac{20}{0.10} + \frac{30}{0.10} \right]$$

$$= 10^{-4} \text{ T, pointing normally inward.}$$

(c) At point r, B_1 points normally inward, and B_2 points normally outward.

$$\therefore B_R = B_2 - B_1 = \frac{4\pi \times 10^{-7}}{2\pi} \left[\frac{30}{0.10} - \frac{20}{0.30} \right]$$

$$= 4.3 \times 10^{-5} \text{ T pointing normally outward}$$

Example:- Two parallel wires P and Q placed at a separation of $r = 6 \text{ cm}$ carry electric current $I_1 = 5 \text{ A}$ and $I_2 = 2 \text{ A}$ in opposite directions as shown in the figure. Find the point on the line PQ where the resultant magnetic field is zero.

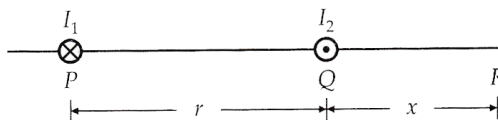

Magnetic Field inside a straight Solenoid:-

A solenoid means an insulated copper wire wound closely in the form of a helix. The word solenoid comes from a Greek word meaning channel and was first used by Ampere. By a long solenoid, we mean that the length of the solenoid is very large as compared to its diameter. The figure shows an enlarged view of the magnetic field due to a section of a solenoid. At various turns of the solenoid, current enters the plane of paper at points marked \otimes and leaves the plane of paper at points marked \otimes . The magnetic field at points close to a single turn of the solenoid is in the form of concentric circles like that of a straight current-carrying wire. The resultant field of the solenoid is the vector sum of the field due to all the turns of the solenoid. Obviously, the fields due to the neighboring turns add up along the axis of the solenoid but they cancel out in the perpendicular direction. At outside points such as Q, the fields of the points marked \otimes tend to cancel out the fields of the points marked \otimes . Thus the field at interior midpoint P is uniform and strong. The field at the exterior midpoint Q is weak and is along the axis of the solenoid with no perpendicular component. The figure shows the field pattern of a solenoid of finite length.

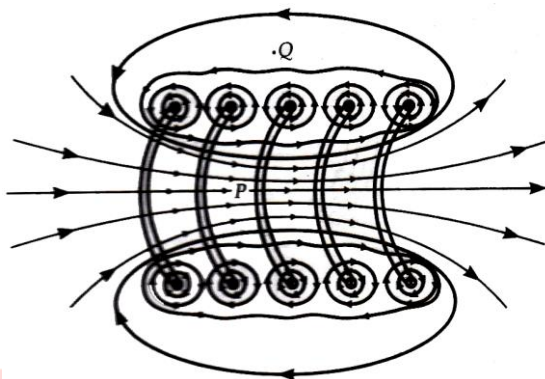

The polarity of any end of the solenoid can be determined by using the clock rule or Ampere's right-hand rule.

Ampere's right-hand rule:- Grasp the solenoid with the right hand so that the fingers point along the direction of the current, the extended thumb will then indicate the face of the solenoid that has north polarity.

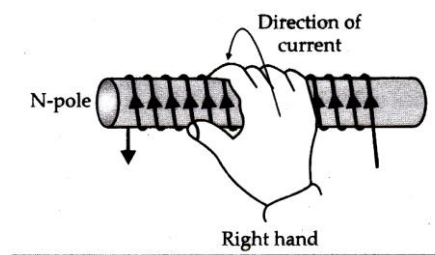

Calculation of magnetic field inside a long straight solenoid:- The magnetic field inside a closely wound long solenoid is uniform everywhere and zero outside it. The figure shows the sectional view of a long solenoid. At various turns of the solenoid, the current comes out of the plane of paper at points marked \odot and enters the plane of paper at points marked \otimes . To determine the magnetic field \vec{B} at any inside point, consider a rectangular closed path $abcd$ as the Amperian loop.

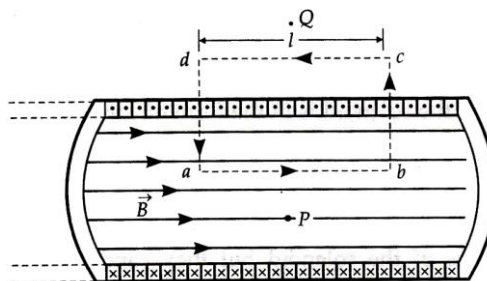

According to Amper's circuital law,

$$\oint \vec{B} \cdot d\vec{\ell}$$

$= \mu_0 \times$ The total current through the loop $abcd$.

$$\text{Now, } \oint \vec{B} \cdot d\vec{\ell} = \int_a^b \vec{B} \cdot d\vec{\ell} + \int_c^d \vec{B} \cdot d\vec{\ell} + \int_d^a \vec{B} \cdot d\vec{\ell}$$

$$\text{But } \int_b^c \vec{B} \cdot d\vec{\ell} = \int_b^c B d\ell \cos 90^\circ = 0$$

$$\int_d^a \vec{B} \cdot d\vec{\ell} = \int_d^a B d\ell \cos 90^\circ = 0$$

$$\int_c^d \vec{B} \cdot d\vec{\ell} = 0 \text{ as } B = 0 \text{ for points outside the solenoid.}$$

$$\therefore \oint \vec{B} \cdot d\vec{\ell} = \int_a^b \vec{B} \cdot d\vec{\ell}$$

$$= \int_a^b B d\ell \cos 0^\circ = B \int_a^b d\ell = B\ell$$

Where,

ℓ = length of the side ab of the rectangular loop $abcd$.

Let the number of turns per unit length of the solenoid = n

Then the number of turns in the length ℓ of the solenoid = $n\ell$

Thus the current I of the solenoid threads the loop $abcd$, $n\ell$ times.

Total current threading the loop $abcd = n\ell I$

Here $B\ell = \mu_0 n\ell I$ or $B = \mu_0 nI$

It can be easily shown that the magnetic field at the end of the solenoid is just one half of that at its middle.

Thus $B_{\text{end}} = \frac{1}{2} \mu_0 nI$

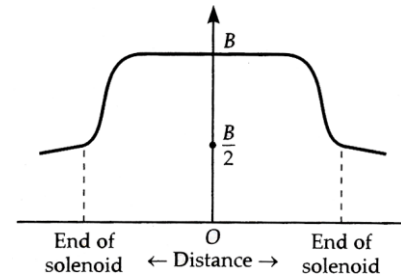

The figure shows the variation of the magnetic field on the axis of a long straight solenoid with distance x from its center.

Magnetic field due to a toroidal solenoid:-

A solenoid bent into the form of a closed ring is called a toroidal solenoid. Alternatively, it is an anchor ring (torus) around which a large number of turns of a metallic wire are wound, as shown in the figure. We shall see that the magnetic field \vec{B} has a constant magnitude everywhere inside the toroid while it is zero in the open space interior (point P) and exterior (point Q) to the toroid. The figure shows a sectional view of the toroidal solenoid. The direction of the magnetic field inside is clockwise as per the right-hand thumb rule for circular loops. Three circular Amperean loops are shown by dashed lines. By symmetry, the magnetic field should be tangential to them and constant in magnitude for each of the loops.

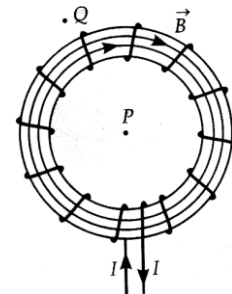

(a) For points in the open space interior to the toroid.

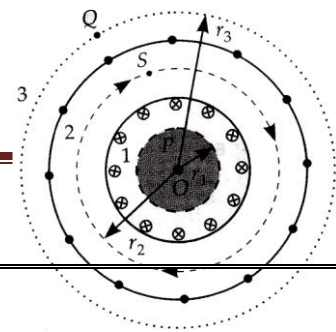

Let B_1 be the magnitude of the magnetic field along the Amperean loop 1 of radius r_1 .

Length of loop 1 of $L_1 = 2\pi r_1$

As the loop encloses no current, so $I = 0$

Applying Ampere's circuital law,

$$B_1 L_1 = \mu_0 I \quad \text{Or } B_1 \times 2\pi r_1 = \mu_0 \times 0 \quad \text{Or } B_1 = 0$$

Thus the magnetic field at any point P in the open space interior to the toroid is zero.

(b) For points inside the toroid.

Let B be the magnitude of the magnetic field along the Amperean loop 2 of radius r.

Length of loop 2, $L_2 = 2\pi r$

If N is the total number of turns in the toroid and I the current in the toroid, then the total current enclosed by the loop $2 = NI$. Applying Ampere's circuital law,

$$B \times 2\pi r = \mu_0 \times NI \quad \text{Or } B = \frac{\mu_0 NI}{2\pi r}$$

If r be the average radius of the toroid and n the number of turns per unit length, then

$$N = 2\pi r n \quad \therefore B = \mu_0 n I$$

(c) For points in the open space exterior to the toroid.

Each turn of the toroid passes twice through the area enclosed by the Amperean loop 3. But for each turn, the current coming out of the plane of paper is canceled by the current going into the plane of the paper. Thus $I = 0$ and hence $B_3 = 0$

Example:- A solenoid coil of 300 turns/m is carrying a current of 5A. The length of the solenoid is 0.5 m and has a radius of 1cm. Find the magnitude of the magnetic field inside the solenoid.

Solution:- Here $n = 300$ turns/m $I = 5$ A

$$\therefore B = \mu_0 n I = 4\pi \times 10^{-7} \times 300 \times 5 = 1.9 \times 10^{-3} T$$

Example:- a solenoid of length 0.5 m has a radius of 1cm and is made up of 500 turns. It carries a current of 5A. What is the magnitude of the magnetic field inside the solenoid?

Solution:-Number of turns per unit length,

$$n = \frac{N}{l} = \frac{500}{0.5m} = 1000 \text{ turns/m}$$

Here $l = 0.5m$ and $r = 0.01m$

i.e $l \gg a$. So we can use the formula for the magnetic field inside along solenoid.

$$B = \mu_0 n l = 4\pi \times 10^{-7} \times 1000 \times 5 = 6.28 \times 10^{-3} T$$

Example:- A 0.5 m long solenoid has 500 turns and has a flux density of $2.52 \times 10^{-3} T$ at the center.

Find the current in the solenoid. Given $\mu_0 = 4\pi \times 10^{-7} Hm^{-1}$.

Solution:- $n = \frac{N}{l} = \frac{500}{0.5m} = 1000 \text{ turns/m}$

As $B = \mu_0 n l \therefore I = \frac{B}{\mu_0 n} = \frac{2.52 \times 10^{-3}}{4\pi \times 10^{-7} \times 1000} = 2.0 A$

ODM
EDUCATIONAL GROUP
Changing your Tomorrow

Force on a moving charge in a magnetic field:-

The electric charges moving in a magnetic field experience a force, while there is no such force on static charges. This fact was first recognized by Hendrik Antoon Lorentz, a great Dutch physicist, nearly a century ago. Suppose a positive charge q moves with velocity \vec{v} in magnetic field \vec{B} and \vec{v} makes an angle θ with \vec{B} , as shown in the figure. It is found from experiment that the charge q moving in the magnetic field \vec{B} experiences a force \vec{F} such that.

- The force is proportional to the magnitude of the magnetic field, i.e. $F \propto B$
- The force is proportional to the charge q , i.e. $F \propto q$

The force is proportional to the component of the velocity v in the perpendicular direction of the field B , i.e. $F \propto v \sin \theta$

Combining the above factors, we get

$$F \propto Bqv \sin \theta \text{ Or } F = kqvB \sin \theta$$

The unit of the magnetic field is so defined that the proportionality constant k becomes unity in the above equation. Thus

$$F = qvB \sin \theta$$

This force deflects the charged particle sideways and is called the magnetic Lorentz force. As the direction of \vec{F} is perpendicular to both \vec{v} and \vec{B} , so we can express \vec{F} in terms of the vector product of \vec{v} and \vec{B} , so we can express \vec{F} in terms of the vector product of \vec{v} and \vec{B} as $\vec{F} = q(\vec{v} \times \vec{B})$

The figure shows the relationship among the directions of vectors \vec{F} , \vec{v} and \vec{B} . Vectors \vec{v} and \vec{B} lie in the XY-plane. The direction of \vec{F} is perpendicular to this plane and points along +z-axis i.e. \vec{F} acts in the direction of $\vec{v} \times \vec{B}$.

Rules for finding the direction of the force on a charged particle moving perpendicular to a magnetic field. The direction of the magnetic Lorentz force \vec{F} can be determined by using either of the following two rules.

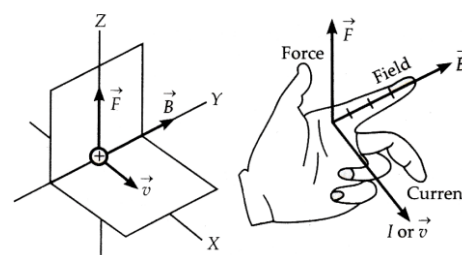
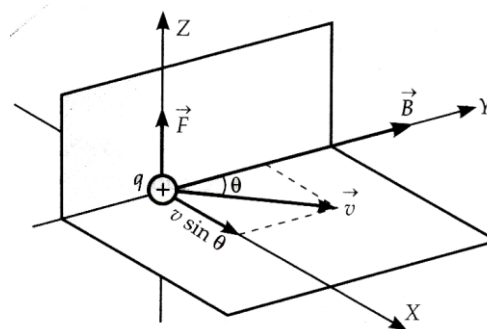

Fleming's Left-hand rule: - Stretch the thumb and the first two fingers of the left hand mutually perpendicular to each other. If the forefinger points in the direction of the magnetic field central finger in the direction of the current, then the thumb gives the direction of the force on the charged particle.

Right hand (palm) rule: - Open the right hand and place it so that the tips of the fingers point in the direction of the field \vec{B} and the thumb in the direction of the velocity \vec{v} of the positive charge, then the palm faces towards the force \vec{F} , as shown in the figure.

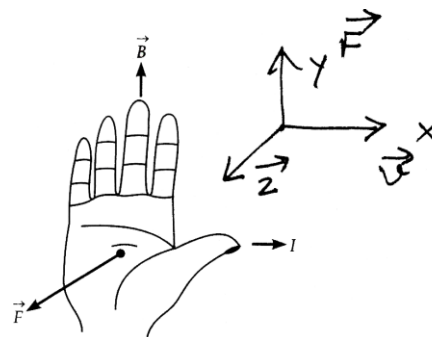

Definition of the magnetic field, we know that $B = \frac{F}{qv \sin \theta}$

If $q = 1, v = 1, \theta = 90^\circ, \sin 90^\circ = 1$, then $B = F$

Thus, the magnetic field at a point may be defined as the force acting on a unit charge moving with a unit velocity at right angles to the direction of the field.

SI unit of the magnetic field.

Again, we use $B = \frac{F}{qv \sin \theta}$

If $F = 1N, q = 1C, v = 1ms^{-1}, \theta = 90^\circ$, then

$$\text{SI unit of } B = \frac{1N}{1C \cdot 1ms^{-1} \cdot \sin 90^\circ}$$

$$= \frac{1N}{1A \cdot 1m} = 1NA^{-1}m^{-1} = 1\text{tesla}$$

Thus, the SI unit of the magnetic field is the **tesla (T)**

One tesla is that a magnetic field in which a charge of 1C moving with a velocity of $1ms^{-1}$ at right angles to the field experiences a force of one newton.

A field of one tesla is a very strong magnetic field. Very often the magnetic fields are expressed in terms of a smaller unit, called the gauss (G)

$$1 \text{ gauss} = 10^{-4} \text{ tesla}$$

Some typical magnetic fields

Surface of a neutron star	$10^8 T$
Large field in the laboratory	$1 T$
Field near a bar magnet	$10^{-2} T$
Field on the earth's surface	$10^{-4} T$
Field in interstellar space	$10^{-12} T$

Dimensions of the magnetic field, clearly,

$$[B] = \frac{[F]}{[q][v][\sin \theta]} = \frac{MLT^{-2}}{AT \cdot LT^{-1}} = \frac{M}{AT^2}$$

Here A represents current.

What is the Lorentz force? Write an expression for it.

The total force experienced by a charged particle moving in a region where both electric and magnetic fields are present is called Lorentz force.

A charge q in an electric field \vec{E} experiences the electric force,

$$\vec{F}_e = q\vec{E}$$

The magnetic force experienced by the charge q moving with velocity \vec{v} in the magnetic field \vec{B} is given by $\vec{F}_m = q(\vec{v} \times \vec{B})$. The total force, or the Lorentz force, experienced by the charge q due to both electric and magnetic field is given by.

$$\vec{F} = \vec{F}_e + \vec{F}_m \quad \text{Or} \quad \vec{F} = q(\vec{E} + \vec{v} \times \vec{B})$$

Example:- A proton enters a magnetic field of flux density 2.5 T with a velocity of $1.5 \times 10^7 \text{ ms}^{-1}$ at an angle of 30° with the field. Find the force on the proton.

Solution:-

Here $q = e = 1.6 \times 10^{-19} \text{ C}$, $v = 1.5 \times 10^7 \text{ ms}^{-1}$, $B = 2.5 \text{ T}$, $\theta = 30^\circ$

Force, $F = qvB \sin \theta$

$$= 1.6 \times 10^{-19} \times 1.5 \times 10^7 \times 2.5 \times \sin 30^\circ = 3 \times 10^{-12} \text{ N}$$

Example:- Copper has 8.0×10^{28} electrons per cubic meter. A copper wire of length 1m and cross-sectional area $8.0 \times 10^{-6} \text{ m}^2$ carrying a current and lying at the right angle to a magnetic field of strength $5 \times 10^{-3} \text{ T}$ experiences a force of $8.0 \times 10^{-2} \text{ N}$. Calculate the drift velocity of free electrons in the wire.

Solution:-

$$n = 8 \times 10^{28} \text{ m}^{-3}, l = 1 \text{ m}$$

$$A = 8 \times 10^{-6} \text{ m}^2, e = 1.6 \times 10^{-19} \text{ C}$$

The total charge contained in the wire,

$$q = \text{volume of wire} \times n e = a l n e$$

$$= 8 \times 10^{-6} \times 1 \times 8 \times 10^{28} \times 1.6 \times 10^{-19} \text{ C}$$

$$= 102.4 \times 10^3 \text{ C}$$

If v_d is the drift speed of electrons, then

$$F = q v_d B \sin 90^\circ = q v_d B$$

$$v_d = \frac{F}{qB} = \frac{8.0 \times 10^{-2}}{102.4 \times 10^3 \times 5 \times 10^{-3}} \text{ ms}^{-1}$$

$$= 1.56 \times 10^{-4} \text{ ms}^{-1}$$

Work done by a magnetic force on a charged particle is zero:-

The magnetic force $\vec{F} = q(\vec{v} \times \vec{B})$ always acts perpendicular to the velocity \vec{v} or the direction of motion of charge q . Therefore

$$\vec{F} \cdot \vec{v} = q(\vec{v} \times \vec{B}) \cdot \vec{v} = 0$$

According to Newton's second law.

$$\vec{F} = m\vec{a} = m \frac{d\vec{v}}{dt}$$

$$\therefore m \frac{d\vec{v}}{dt} \cdot \vec{v} = 0$$

$$\text{Or } \frac{m}{2} \left[\frac{d\vec{v}}{dt} \cdot \vec{v} + \vec{v} \cdot \frac{d\vec{v}}{dt} \right] = 0$$

$$\text{Or } \frac{m}{2} \frac{d}{dt} (\vec{v} \cdot \vec{v}) = 0$$

$$\text{Or } \frac{d}{dt} \left(\frac{1}{2} mv^2 \right) = 0 \quad \text{Or } \frac{d}{dt} \left(\frac{1}{2} mv^2 \right) = 0$$

$$\text{Or } \frac{dK}{dt} = 0$$

$K = \text{constant}$

Thus a magnetic force does not change the kinetic energy of the charged particle. This indicates that the speed of the particle does not change. According to the work-energy theorem, the change in kinetic energy is equal to the work done on the particle by the net force. Hence the work done on the charged particle by the magnetic force is zero.

The motion of a charged particle in a uniform magnetic field: -

Discuss the motion of a charged particle in a uniform magnetic field with initial velocity (a) parallel to the field (b) perpendicular to the magnetic field and (c) at an arbitrary angle with the field direction.

When a charged particle having charge q and velocity \vec{v} enters a magnetic field \vec{B} , it experiences a force.

$$\vec{F} = q(\vec{v} \times \vec{B})$$

The direction of this force is perpendicular to both \vec{v} and \vec{B} . The magnitude of this force is

$$F = qvB \sin \theta$$

The following three cases are possible.

When the initial velocity is parallel to the magnetic field

Here $\theta = 0^\circ$, So $F = qvB \sin 0^\circ = 0$

Thus, the parallel magnetic field does not exert any force on the moving charged particle. The charged particle will continue to move along the line of force.

When the initial velocity is perpendicular to the magnetic field

Here $\theta = 90^\circ$, So $F = qvB \sin 90^\circ = qvB = a$ maximum force.

As the magnetic force acts on a particle perpendicular to its velocity, it does not do any work on the particle. It does not change the kinetic energy or speed of the particle. The figure shows a

magnetic field \vec{B} directed normally into the plane of the paper, as

shown by small crosses. A charge $+q$ is projected with a speed v in the plane of the paper. The velocity is perpendicular to the magnetic field. A force $F = qvB$ acts on the particle perpendicular to both \vec{v} and \vec{B} . This force continuously deflects the particle sideways without changing its speed and the particle will move along a circle perpendicular to the field.

Clearly, the time period is independent of v and r . If the particle moves faster, the radius is larger, it has to move along a large circle so that the time taken is the same.

The frequency of revolution is

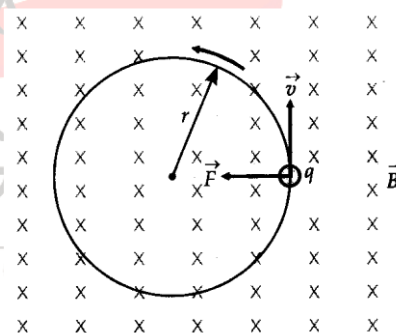

$$f_c = \frac{1}{T} = \frac{qB}{2\pi m}$$

This frequency is called cyclotron frequency

When the initial velocity makes an arbitrary angle with the field direction

A uniform magnetic field \vec{B} is set up along the +ve X-axis.

A particle of charge q and mass m enters the field \vec{B} with velocity \vec{v} inclined at an angle θ with the direction of the field \vec{B} , as shown in the figure.

The velocity \vec{v} can be resolved into two rectangular components

The component v_{\parallel} along the direction of the field i.e along the X-axis. Clearly $v_{\parallel} = v \cos \theta$. The parallel component remains unaffected by the magnetic field and so the charged particle continues to move along the field with a speed of $v \cos \theta$.

The component v_{\perp} perpendicular to the direction of the field i.e in the YZ-plane.

Clearly $v_{\perp} = v \sin \theta$. Due to this component of velocity, the charged particle experiences a force

$F = qv_{\perp}B$ that acts perpendicular to both v_{\perp} and \vec{B} .

$$r = \frac{mv_{\perp}}{qB} = \frac{mv \sin \theta}{qB}$$

The period of revolution is $T = \frac{2\pi r}{v_{\perp}} = \frac{2\pi}{v \sin \theta} \cdot \frac{mv \sin \theta}{qB} = \frac{2\pi m}{qB}$

Thus, a charged particle moving in a uniform magnetic field has two concurrent motions a linear motion in the direction of \vec{B} (along X-axis) and a circular motion in a plane perpendicular to \vec{B} (in YZ plane). Hence the resultant path of the charged particle will be a helix, with its axis along the direction of \vec{B} . The linear distance travelled by the charged particle in the direction of the magnetic field during its period of revolution is called the pitch of the helical path.

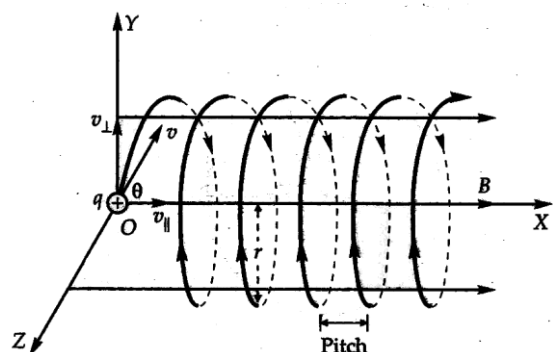

$$\text{Pitch} = v_{\parallel} \times T = v \cos \theta \times \frac{2\pi}{qB} = \frac{2\pi m v \cos \theta}{qB}$$

Velocity selector:- As shown in the figure the electric field \vec{E} acts in the downward direction and deflects the electrons in the upward direction. The magnetic field \vec{B} acts normally into the plane of the paper and deflects the electrons the downward direction.

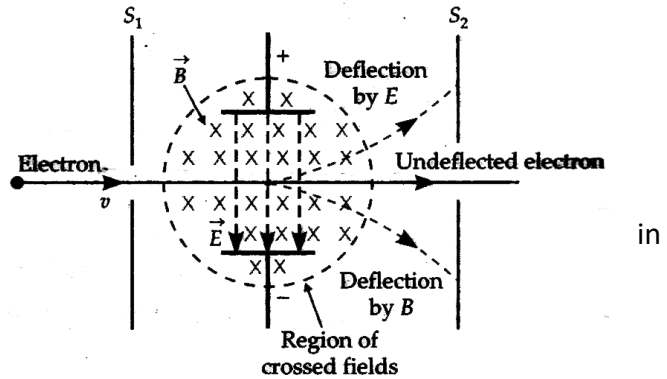

Only those electrons will pass unselected through

the slit S_2 on which the electric and magnetic forces are equal and opposite. The velocity v of the unselected electrons is given by. $eE = evB$ or $v = \frac{E}{B}$

Such an arrangement can be used to select charged particles of a particular velocity out of a beam in which the particles are moving with different speeds. This arrangement is called the velocity selector or velocity filter. This method was used by J.J. Thomson to determine the charge to mass ratio (e/m) of an electron.

Example:- An electron after being accelerated through a potential difference of 10^4 V enters a uniform magnetic field of 0.04 T perpendicular to its direction of motion. Calculate the radius of the curvature of its trajectory.

Solution:- Here, $V = 10^4$ V, $B = 0.04$ T, $e = 1.6 \times 10^{-19}$ C, $m = 9.1 \times 10^{-31}$ kg

An electron accelerated through a p.d. V acquires a velocity v given by

$$\frac{1}{2}mv^2 = eV \quad \text{or} \quad v = \sqrt{\frac{2eV}{m}}$$

As the electron describes a circular path a radius of r in the perpendicular magnetic field B , therefore,

$$\frac{mv^2}{r} = evB$$

$$\text{Or } r = \frac{mv}{eB} = \frac{m}{eB} \sqrt{\frac{2eV}{m}} = \frac{\sqrt{2meV}}{eB} = \frac{\sqrt{2 \times 9.1 \times 10^{-31} \times 1.6 \times 10^{-19} \times 10^4}}{1.6 \times 10^{-19} \times 0.04}$$

$$= \frac{5.4 \times 10^{-23}}{1.6 \times 10^{-19} \times 0.04} = 8.43 \times 10^{-3} \text{ m} = 8.43 \text{ mm}$$

Example:- If a particle of charge q is moving with velocity v along the z -axis and the magnetic field B is acting along the x -axis, use the expression $\vec{F} = q(\vec{v} \times \vec{B})$ to find the direction of the force F acting on it. A beam of proton passes undeflected with a horizontal velocity v , through a region of electric and magnetic fields, mutually perpendicular to each other and normal to the direction of the beam. If the magnitudes of the electric and magnetic fields are 100 kV/m and 50 mT respectively, calculate (a) velocity v of the beam. (b) the force with which it strikes a target on a screen if the proton beam cutting is equal to 0.80 mA .

Solution:-

$$\vec{F} = q(\vec{v} \times \vec{B}) = q(v\hat{j} \times B\hat{k})$$

$$qvB\hat{j} \times \hat{k} = qvB\hat{i}$$

Thus the force F acts on the charge q along the +ve x -direction.

(a) For undeflected proton beam, $qvB = qE$

$$v = \frac{E}{B} = \frac{100 \text{ kVm}^{-1}}{50 \text{ mT}} = \frac{100 \times 10^3 \text{ Vm}^{-1}}{50 \times 10^{-3} \text{ T}}$$

$$= 2 \times 10^6 \text{ ms}^{-1}$$

(b) The current carried by proton beam, $I = 0.8 \text{ mA} = 8 \times 10^{-4} \text{ A}$

Number of protons striking the screen per second,

$$n = \frac{I}{e} = \frac{8 \times 10^{-4}}{1.6 \times 10^{-19}} = 5 \times 10^{15} \text{ s}^{-1}$$

$$m_p = 1.675 \times 10^{-27} \text{ kg}$$

The force with which a proton beam strikes a target on the screen,

$$F = \frac{dp}{dt} = m_p n v$$

$$= 1.675 \times 10^{-27} \times 5 \times 10^{15} \times 2 \times 10^6 \text{ N}$$

$$= 1.675 \times 10^{-5} \text{ N}$$

Cyclotron:-

It is a device used to accelerate charged particles like protons, deuterons, α particles, etc. to very high energies. It was invented by E.O Lawrence and M.S. Livingston in 1934 at Berkeley. California University.

Principle:- A charged particle can be accelerated to very high energies by making it pass through a moderate electric field a number of times. This can be done with the help of a perpendicular magnetic field which throws the charged particle into a circular motion, the frequency of which does not depend on the speed of the particle and the radius of the circular orbit.

Construction:- As shown in figure a cyclotron consists of the following main parts

- It consists of two small, hollow, metallic half-cylinders D_1 and D_2 called dees as they are in the shape of D.
- They are mounted inside a vacuum chamber between the poles of a powerful electromagnet.
- The dees are connected to the source of the high-frequency alternating voltage of a few hundred kilovolts.
- The beam of charged particles to be accelerated is injected into the dees near their center, in a plane perpendicular to the magnetic field.
- The charged particles are pulled out of the dees by a deflecting plate (which is negatively charged) through a

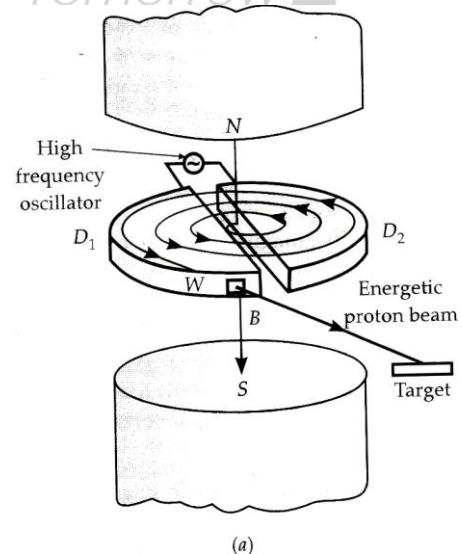

window W.

- The whole device is in a high vacuum (pressure $\sim 10^{-6}$ mm of Hg) so that the air molecules may not collide with the charged particles.

Theory:- Let a particle of charge q and mass m enter a region of the magnetic field \vec{B} with a velocity \vec{v} , normal to the field \vec{B} . The particle follows a circular path, the necessary centripetal force being provided by the magnetic field. Therefore,

Magnetic force on charge q = Centripetal force on charge q

$$\text{Or } qvB \sin 90^\circ = \frac{mv^2}{r} \text{ or } r = \frac{mv}{qB}$$

The period of revolution of the charged particle is given by.

$$T = \frac{2\pi r}{v} = \frac{2\pi}{v} \cdot \frac{mv}{qB} = \frac{2\pi m}{qB}$$

Hence the frequency of revolution of the particle will be $f_c = \frac{1}{T} = \frac{qB}{2\pi m}$. Clearly, this frequency is

independent of both the velocity of the particle and the radius of the orbit and is called cyclotron frequency or magnetic resonance frequency. This is the key fact which is made use of in the operation of a cyclotron.

Working: -

Suppose a positive ion, say a proton, enters the gap between the two dees and finds dee D_1 to be negative. It gets accelerated towards dee D_1 . As it enters the dee D_1 , it does not experience any electric field due to the shielding effect of the metallic dee. The perpendicular magnetic field throws it into a circular path. At the instant the proton comes out of dee D_1 , it finds dee D_1 positive and dee D_2 negative. It now gets accelerated towards dee D_2 . It moves faster through D_2 describing a larger semicircle than before. Thus if the frequency of the applied voltage is kept exactly the same as the

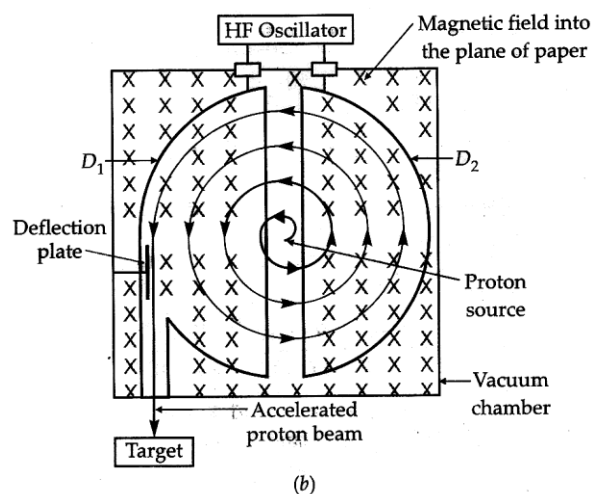

frequency of revolution of the proton, then every time the proton reaches the gap between the two dees, the electric field is reversed and the proton receives a push and finally, it acquires very high energy. This is called cyclotron's resonance condition. The proton follows a spiral path. The accelerated proton is ejected through a window by a deflecting voltage and hits the target.

Maximum K.E of the accelerated ions:-

The ions will attain maximum velocity near the periphery of the dees. If v_0 is the maximum velocity acquired by the ions and r_0 is the radius of the dees, then

$$\frac{mv_0^2}{r_0} = qv_0B \text{ or } v_0 = \frac{qBr_0}{m}. \text{ The maximum kinetic energy of the ions will be } K_0 = \frac{1}{2}mv_0^2 = \frac{1}{2}m\left(\frac{qBr_0}{m}\right)^2$$

$$\text{Or } K_0 = \frac{q^2B^2r_0^2}{2m}$$

Limitations of cyclotron:-

- According to Einstein's special theory of relativity, the mass of a particle increases with the increase in its velocity as. $m = \frac{m_0}{\sqrt{1-v^2/c^2}}$, where m_0 is the rest mass of the particle. At high velocities, the cyclotron frequency ($f_c = qB/2\pi m$) will decrease due to the increase in mass. This will throw the particles out of resonance with the oscillating field. That is, as the ions reach the gap between the dees, the polarity of the dees is not reversed at that instant. Consequently, the ions are not accelerated further. The above drawback is overcome either by increasing the magnetic field as in a synchrotron or by decreasing the frequency of the alternating electric field as in a synchrocyclotron.
- Electrons cannot be accelerated in a cyclotron. A large increase in their energy increases their velocity to a very large extent. This throws the electrons out of step with the oscillating field.
- Neutrons, being electrically neutral, cannot be accelerated in a cyclotron.

Uses of cyclotron:-

- The high energy particles produced in a cyclotron are used to bombard nuclei and study the resulting nuclear reactions and hence investigate nuclear structure.
- The high energy particles are used to produce other high energy particles, such as neutrons, by collisions. These fast neutrons are used in atomic reactions.
- It is used to implant ions into solids and modifies their properties or even synthesis new materials.
- It is used to produce radioactive isotopes that are used in hospitals for diagnosis and treatment.

Example:- In a cyclotron, a magnetic induction of 1.4 T is used to accelerate protons. How rapidly should the electric field between the dees be reversed? The mass and charge of the proton are $1.67 \times 10^{-27} \text{ kg}$ and $1.6 \times 10^{-19} \text{ C}$ respectively.

Solution:-

$$B = 1.4 \text{ T}, m = 1.67 \times 10^{-27} \text{ kg}$$

$$e = 1.6 \times 10^{-19} \text{ C}$$

The time required by a charged particle to complete a semicircle in a dee is.

$$t = \frac{\pi m}{eB} = \frac{3.14 \times 1.67 \times 10^{-27}}{1.6 \times 10^{-19} \times 1.4} = 2.34 \times 10^{-8} \text{ s} .$$

Thus the direction of the electric field should reverse after every $2.34 \times 10^{-8} \text{ s}$.

The frequency of the applied electric field should be.

$$f_c = \frac{1}{2t} = \frac{1}{2 \times 2.34 \times 10^{-8}} = 2.14 \times 10^7 \text{ Hz}$$

Example:- If the maximum value of accelerating potential provided by a radio frequency oscillator be 20 kV, find the number of revolutions made by a proton in a cyclotron to achieve one-fifth of the speed of light. Mass of a proton = $1.67 \times 10^{-27} \text{ kg}$.

Solution:-

In a cyclotron, a proton gains energy eV, when it crosses a region of potential difference V. In one revolution, the particle crosses the gap twice. So the energy gained in each revolution = 2 eV. Suppose the particle makes n revolutions before emerging from the dees. The gain in its kinetic energy will be.

$$\frac{1}{2} mv^2 = 2neV \text{ or } n = \frac{mv^2}{4eV}$$

$$\text{Given } v = \frac{c}{5} = \frac{3 \times 10^8}{5} = 0.6 \times 10^8 \text{ ms}^{-1}$$

$$m = 1.67 \times 10^{-27} \text{ kg}$$

$$\therefore n = \frac{1.67 \times 10^{-27} \times (0.6 \times 10^8)^2}{4 \times 1.6 \times 10^{-19} \times 20 \times 10^3} = 470 \text{ revolutions.}$$

Force on a current-carrying conductor in a magnetic field:-

When a conductor carrying a current is placed in an external magnetic field, it experiences a mechanical force. To demonstrate this force, take a small aluminium rod AB. Suspend it horizontally by means of connecting wires from a stand, as shown in the figure.

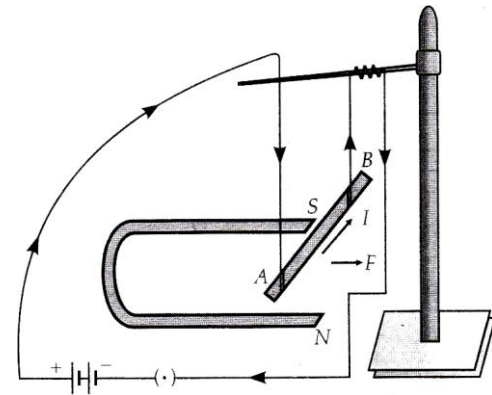

Place a strong horseshoe magnet in such a way that the rod is between the two poles with the field directed upwards. Now,

it current is passed through the rod from A to B, the rod gets deflected to the right. If we reverse the direction of the current or interchange the poles of the magnet, the deflection of the rod is also reversed. The direction of force is perpendicular to both the current and the magnetic field and is given by Fleming's left-hand rule.

Cause of the force on a current-carrying conductor in a magnetic field. Current is an assembly of moving charges and a magnetic field exerts a force on a moving charge. That is why a current-carrying conductor, when placed in the magnetic field experiences a sideways force as the force experienced by the moving charges (free electrons), is transmitted to the conductor as a whole.

As shown in figure consider a conductor PQ of length l , area of cross section A , carrying current I along +ve Y-direction. The field \vec{B} acts along +ve Z-direction. The electrons drift towards left with velocity \vec{v}_d . Each electron experiences a magnetic Lorentz force along +ve X-axis, which is given by

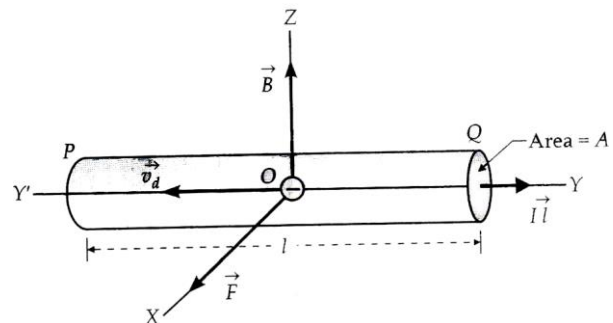

$$\vec{f} = -e(\vec{v}_d \times \vec{B})$$

If n is the number of free electrons per unit volume, then the total number of electrons in the conductor is

$$N = n \times \text{volume} = nAl$$

The total force on the conductor is

$$\vec{F} = N\vec{f} = nAl[-e(\vec{v}_d \times \vec{B})]$$

$$= enA[-l\vec{v}_d \times \vec{B}]$$

If $I\vec{l}$ represents a current element vector in the direction of the current, then the vector \vec{l} and \vec{v}_d will have opposite directions and we can take.

$$-l\vec{v}_d = v_d\vec{l} \quad \therefore \vec{F} = enAv_d(\vec{l} \times \vec{B})$$

But $enAv_d = \text{current, } I$ Hence $\vec{F} = I(\vec{l} \times \vec{B})$

The magnitude of force:- The magnitude of the force on the current-carrying conductor is given by

$$F = I l B \sin \theta,$$

where θ is the angle between the direction of the magnetic field and the direction of flow of current?

Special cases

(a) If $\theta = 0^\circ$ or 180° , then $F = I l B(0) = 0$. Thus a current-carrying conductor placed parallel to the direction of the magnetic field does not experience any force.

(b) If $\theta = 90^\circ$, then $F = I l B \sin 90^\circ = I l B$, or $F_{\max} = I l B$. Thus a current-carrying conductor placed perpendicular to the direction of the magnetic field experiences a maximum force.

The direction of force:- The direction of the force on a current-carrying conductor placed in a perpendicular magnetic field is given by Fleming's left-hand rule. Stretch the thumb and the first two fingers of the left hand in mutually perpendicular directions. If the forefinger points in the direction of the magnetic field, the central finger in the direction of the current, then the thumb gives the direction

of the force on the conductor. If figure the field \vec{B} is along +Z-direction, the current I along +Y-direction and so the force \vec{F} acts along + X-direction.

Example:-

A straight wire of mass 200 g and length 1.5 cm carries a current of 2A. It is suspended in mid-air by a uniform magnetic field (B). What is the magnitude of the magnetic field?

Solution:-

$$I = 2A, \ell = 1.5m, m = 0.2kg$$

$$I\ell B = mg$$

$$\Rightarrow B = \frac{mg}{I\ell} = \frac{0.2 \times 9.8}{2 \times 1.5} = 6.53T$$

Example:-

What is the magnitude of magnetic force per unit length on a wire carrying a current of 8A and making an angle of 30° with the direction of a uniform magnetic force of 0.15 T

Solution:-

$$\text{Given } I = 8A, \theta = 30^\circ, B = 0.15$$

$$\text{We know } F = I\ell B \sin \theta$$

$$\frac{\text{Force}}{\text{Length}} = \frac{F}{\ell} = IB \sin \theta = 8 \times 0.15 \times \sin 30^\circ = 0.60N/m$$

Numerical:-

A 3 cm wire carrying a current of 10A is placed inside a solenoid perpendicular to its coils. The magnetic field inside the solenoid is 0.27 T. What is the magnetic force on the wire.

Numerical:-

A conductor of length 50 cm carrying a current of 2.5 A experiences a maximum force of 0.15 N when kept in a uniform magnetic field. Find the magnitude and direction of the magnetic field.

Example:- A wire of length l carries a current I along the X-axis. A magnetic field $\vec{B} = B_0(\hat{i} + \hat{j} + \hat{k})$ tesla exists in space. Find the magnitude of the magnetic force on the wire.

Solution:-

As the wire carries current I along the X-axis, so $\vec{l} = l\hat{i}$

Also, $\vec{B} = B_0(\hat{i} + \hat{j} + \hat{k})$ tesla

Magnetic force on the wire is

$$\vec{F} = I(\vec{l} \times \vec{B}) = I[l\hat{i} \times B_0(\hat{i} + \hat{j} + \hat{k})]$$

$$= B_0 Il [\hat{i} \times (\hat{i} + \hat{j} + \hat{k})]$$

$$= B_0 Il [\hat{i} \times \hat{i} + \hat{j} + \hat{i} \times \hat{k}]$$

$$= B_0 Il (\vec{0} + \hat{k} - \hat{j}) = (\hat{k} - \hat{j}) B_0 Il$$

The magnitude of the magnetic force is *Changing your Tomorrow* 

$$F = \sqrt{1^2 + (-1)^2} B_0 Il = \sqrt{2} B_0 Il \text{ newton.}$$

Example:- The horizontal component of the earth's magnetic field at a certain place is $3.0 \times 10^{-5} T$ and the direction of the field is from the geographic south to the geographic north. A very long straight conductor is carrying a steady current of 1A. What is the force per unit length on it when it is placed on a horizontal table and the direction of the current is (a) east to west, (b) south to north?

Solution:-

The force on a conductor of length l placed in a magnetic field B , and carrying current I , is

$$F = IlB \sin \theta$$

The force per unit length will be $f = \frac{F}{l} IB \sin \theta$

Where θ is the angle that the conductor makes with the direction of \vec{B}

(a) When the current flows east to west, $\theta = 90^\circ$

$$\begin{aligned} \therefore f &= IB \sin 90^\circ = 1 \times 3.0 \times 10^{-5} \times 1 \\ &= 3.0 \times 10^{-5} \text{ Nm}^{-1} \end{aligned}$$

According to Fleming's left-hand rule, this force acts vertically downwards.

(b) When the current flows from south to north, $\theta = 0^\circ$

$$\therefore F = Il \sin 0^\circ = 0$$

Thus the force per unit length of the conductor is zero.

The force between two parallel current-carrying conductors:-.

It was first observed by Ampere in 1820 that two parallel straight conductors carrying currents in the same direction attract each other and those carrying currents in the opposite directions repel each other.

Experiment – 1

As shown in the figure the upper ends of two wires are connected to the –ve terminal of a battery and their lower ends are connected to the +ve terminal of the battery through a mercury bath. When the circuit is completed, the current flow in the two wires in the same direction.

The two wires are found to be closer to each other, indicating a force of attraction between them.

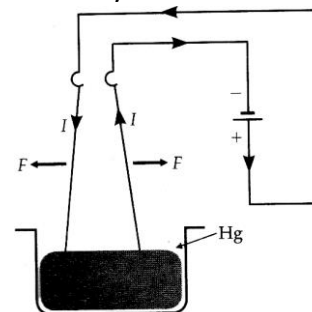

Experiment – 2

As shown in figure two wires are connected to a battery through a

mercury bath in such a way those current flows in them in succession. When the circuit is closed, the currents in the two wires flow in opposite directions. The two wires move away from each other, indicating a force of repulsion between them.

As shown in figure consider two long parallel wires AB and CD carrying currents I_1 and I_2 .

Let r be the separation between them. The magnetic field produced by current I_1 at any point on wire CD is.

$$B_1 = \frac{\mu_0 I_1}{2\pi r}$$

This field acts perpendicular to the wire CD and points into the plane of the paper. It exerts a force on current-carrying wire CD. The force acting on length l of the wire CD will be.

$$F_2 = I_2 l B_1 \sin 90^\circ = I_2 l \cdot \frac{\mu_0 I_1}{2\pi r} = \frac{\mu_0 I_1 I_2}{2\pi r} l$$

$$\text{Force per unit length, } f = \frac{F_2}{l} = \frac{\mu_0 I_1 I_2}{2\pi r}$$

According to Fleming's left-hand rule, this force acts at right angles to CD, towards AB in the plane of the paper. Similarly, an equal force is exerted on the wire AB by the field of wire CD. Thus when the currents in the two wires are in the same direction, the forces between them are attractive. It can be easily seen that

$$\vec{F}_1 = -\vec{F}_2$$

As shown in the figure when the currents in the two parallel wires flow in opposite directions (anti-parallel), the forces between the two wires are repulsive. Thus,

Parallel currents attract and anti-parallel currents repel.

Definition of ampere.

When $I_1 = I_2 = 1A$ and $r = 1m$

$$\text{We get } f = \frac{\mu_0}{2\pi} = 2 \times 10^{-7} \text{ Nm}^{-1}$$

One ampere is that value of steady current, which on flowing in each of the two parallel infinitely long conductors of negligible cross-section placed in vacuum at a distance of 1m from each other, produces between them a force of 2×10^{-7} newton per meter of their length.

Definition of coulomb in terms of ampere.

If a steady current of 1 ampere is set up in a conductor, then the quantity of charge that flows through its cross-section in 1 second is called one coulomb.

$$1\text{C} = 1\text{As}$$

Example:- A current 5.0 A flows through each of two parallel long wires. The wires are 2.5 cm apart. Calculate the force acting per unit length of each wire. Use the standard value of the constant required. What will be the nature of the force, if both currents flow in the same direction?

Solution:- Here $I_1 = I_2 = 5\text{A}$

$$r = 2.5\text{cm} = 2.5 \times 10^{-2} \text{m}, \mu_0 = 4\pi \times 10^{-7} \text{TmA}^{-1}$$

Force acting per unit length of each wire,

$$f = \frac{\mu_0 I_1 I_2}{2\pi r} = \frac{4\pi \times 10^{-7} \times 5 \times 5}{2\pi \times 2.5 \times 10^{-2}} = 2 \times 10^{-4} \text{ Nm}^{-1}.$$

As the currents in both the wires flow in the same direction, the force will be attractive.

Example:- A current balance (or ampere balance) is a device for measuring currents. The current to be measured is arranged to go through two long parallel wires of equal length in opposite directions one of which is linked to the pivot of the balance. The resulting repulsive force on the wire is balanced by putting a suitable mass in the scale pan hanging on the other side of the pivot. In one measurement, the mass in the scale pan is 30.0 g, the length of the wires is 50.0 cm each, and the separation between them is 10.0 mm. What is the value of the current being measured? Take $g = 9.80\text{ms}^{-2}$ and assume that the arms of the balance are equal.

Solution:- $M = 30.0\text{g} = 0.03\text{kg}$, $l = 50\text{cm} = 0.50\text{m}$, $r = 10.0\text{mm} = 0.01\text{m}$, $g = 9.8\text{ms}^{-2}$

Force per unit length between two parallel conductors,

$$f = \frac{\mu_0}{2\pi} \cdot \frac{I_1 I_2}{r} \quad \therefore \text{Force on a conductor of length } l,$$

$$F = \frac{\mu_0}{2\pi} \cdot \frac{I_1 I_2 l}{r} \text{ When the pan is balanced,}$$

Weight in scale pan = Balancing force

$$\text{i.e } mg = \frac{\mu_0}{2\pi} \cdot \frac{I \times I}{r} \cdot l$$

$$\text{Or } I^2 = \frac{2\pi mgr}{\mu_0 l} = \frac{2\pi \times 0.03 \times 9.8 \times 0.01}{4\pi \times 10^{-7} \times 0.05} = 29400 \quad \therefore I = \sqrt{29400} = 171.46 \text{ A}$$

The problem for Practice:-

- A long horizontal rigidly supported wire carries a current of 100A. Directly above it and parallel to it is a fine wire that carries a current of 200 A and weighs 0.05 Nm^{-1} . How far above the wire should the second wire be kept to support it by magnetic repulsion?
- A wire AB is carrying a steady current of 12A and is lying on the table. Another wire CD carrying 5A is held directly above AB at a height of 1mm. Find the mass per unit length of the wire CD so that it remains suspended at its position when left free. Give the direction of the current flowing in CD with respect to the in AB.
- A current of 1A flows in a wire of length 0.1 m in a magnetic field of 0.5 T. Calculate the force acting on the wire when the wire makes an angle of (a) 90° (b) 0° , with respect to the magnetic field.
- A current of 5.0 A is flowing upward in a long vertical wire placed in a uniform horizontal northward magnetic field of 0.02 J. How much force and in what direction will the riled exert on 0.06 m length of the wire?
- What is the magnitude of the force on a wire of length 0.04 m placed inside a solenoid near its center, making an angle of 30° with its axis? The wire carries a current of 12A and the magnetic field due to the solenoid is of magnitude 0.25 T.
- A long straight conductor P carrying a current of 2A is placed parallel to a short conductor Q of length 0.05 m carrying a current of 3A. The two conductors are 0.10 m apart. Calculate (a) the magnetic field due to P at Q (b) the approximate force on Q.

Torque on a rectangular current loop in a uniform magnetic field:-

Let us consider a rectangular loop PQRS in a uniform magnetic field lying in the plane of the paper (XOY). The current flowing (acw) through the loop is I and l , b are its length and breadth respectively.

Since the arms PQ and RS are parallel to \vec{B} , the force acting on each arm is zero.

Force acting on arm PS, i.e, $F = IlB$

Force acting on arm QR i.e, $F = IlB$

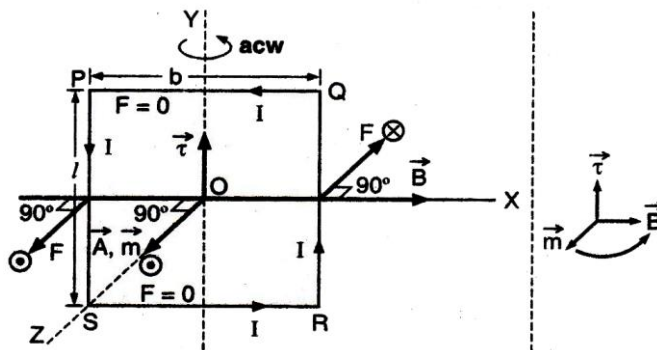

The directions of these forces, according to

Fleming's left-hand rule, are perpendicular to the plane of the paper, one pointing outwards \odot and other inwards \otimes as shown in the figure.

Since these forces (F.F) are parallel to each other and act in opposite directions at different points, they form a couple; b is the arm of this couple.

Moment of the couple (i.e torque)

$$\tau = F \times b = (IlB)b$$

$$\tau = IAB \quad (\text{as } lb = A \text{ the area of the loop})$$

The torque $\vec{\tau}$ rotates the loop scq and as such is represented as shown.

A convenient vector notation for the above equation is.

$$\vec{\tau} = I \vec{A} \times \vec{B} \dots\dots\dots (1)$$

Here, \vec{A} is the area vector of the loop whose direction is determined by the right-hand rule (by wrapping the fingers of the right hand in the direction of the current, the thumb points in the direction of \vec{A}). $\vec{\tau}$ lies in the plane of the paper and is acting upwards.

Current loop as a magnetic dipole:-

Comparing equation (1) with the equation for the torque acting on a magnetic dipole of the magnetic moment \vec{m} in a uniform magnetic field \vec{B}

$$\vec{\tau} = \vec{m} \times \vec{B} = MB \sin \theta$$

We find that $\vec{m} = I \vec{A}$ (2)

Thus, a current-carrying loop behaves as a bar magnet with its one face as the south pole and the other face as the north pole. In the figure, the front face of the loop is the north pole and the back face is the south pole. If we look at the front face of the loop, the current is in the anticlockwise (acw) direction. As such, the front face is the north-seeking pole. The SI unit of magnetic moment is Am^2 .

Case – I (If $\theta = 0^\circ$, \vec{B} is \perp to plane of loop or $\theta = 180^\circ$)

$$\Rightarrow \tau = MB \sin 0^\circ = 0$$

Case – II (If $\theta = 90^\circ$, \vec{B} is parallel to the plane of the loop)

$$\Rightarrow \tau = MB \sin 90^\circ = MB$$

Note:- Torque (τ) remains constant even when the planar current loop is of arbitrary shape.

Question:-

A rectangular coil of sides 8 cm and 6 cm having 2000 turns and carrying a current of 200 mA is placed in a magnetic field of 0.2 T directed along X-axis

- (a) What is the maximum torque the coil can experience? In which orientation does it experience the maximum torque?
- (b) For which orientation of the coil is the torque zero? When is this equilibrium stable and when is it unstable?

Solution:-

$$(a) N = 2000, I = 200 \times 10^{-3} \text{ A}, B = 0.2 \text{ T}, A = 48 \times 10^{-4} \text{ m}^2$$

$$\tau = NIAB \sin \theta \text{ If } \theta = 90^\circ$$

$$\Rightarrow \tau \text{ is maximum}$$

$$\Rightarrow \tau = NIAB = 2000 \times 48 \times 10^{-4} \times 200 \times 10^{-3} \times 0.2 = 0.384 \text{ Nm}$$

Here plane of coil coincides with XZ or XY plane

(b) τ is minimum when $\theta = 0^\circ$ or 180° . This happens, when the plane of the coil coincides with YZ plane.

(i) The coil is said to be in stable equilibrium when \vec{A} is parallel to B and

(ii) Unstable equilibrium with \vec{A} is anti-parallel to B

Question:-

A uniform magnetic field 3000 G is established had along +Z direction. A rectangular loop of sides 10 cm and 5 cm carries Q current of 12 A. What is the torque on the loop in the different cases shown in the figure? What is the force on each side? Which case corresponds to a stable equilibrium?

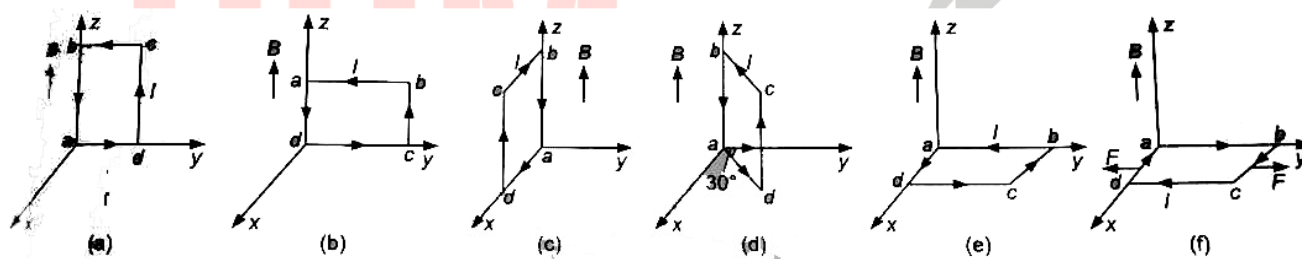

Moving Coil Galvanometer:-

A galvanometer is a device to detect current in a circuit. The commonly used moving coil galvanometer is named so because it uses a current-carrying coil that rotates (or moves) in a magnetic field due to the torque acting on it.

In a D' Arsonval galvanometer, the coil is suspended on a phosphor-bronze wire. It is highly sensitive and requires careful handling. In the Weston galvanometer, the coil is pivoted between two jeweled bearings. It is rugged and portable though less sensitive, and is generally used in laboratories. The basic principle of both types of galvanometers is the same.

Principle:- A current-carrying coil placed in a magnetic field experiences a current dependent torque, which tends to rotate the coil and produces angular deflection.

Construction:- As shown in the figure, a Weston (pivoted type) galvanometer consists of a rectangular coil of fine insulated copper wire wound on a light non-magnetic metallic (aluminum) frame. The two ends of the axle of this frame are pivoted between two jeweled bearings. The motion of the coil is controlled by a pair of hairsprings of phosphor bronze. The inner ends of the springs are soldered to the two ends of the coil and the counter ends are connected to the binding screws. The springs provide the restoring torque and serve as current leads. A light aluminum pointer attached to the coil measures its deflection on a suitable scale.

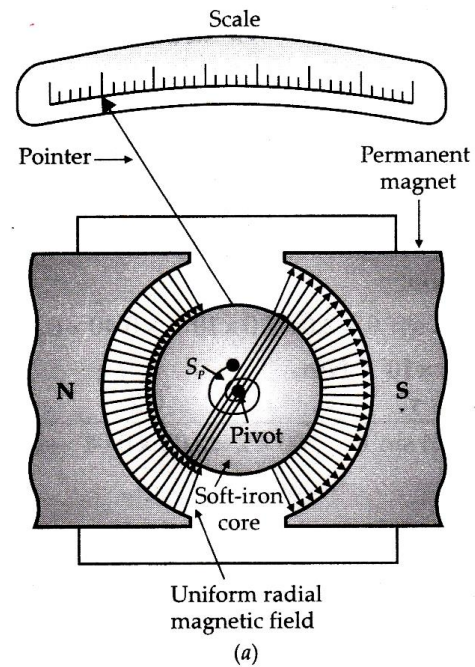

The coil is symmetrically placed between the cylindrical pole pieces of a strong permanent horseshoe magnet.

A cylindrical soft iron core is mounted symmetrically between the concave poles of the horseshoe magnet. This makes the lines of force pointing along the radii of a circle. Such a field is called a radial field. The plane of a coil rotating in such a field remains parallel to the field in all positions, as shown in figure (a) also, the soft iron cylinder, due to its high permeability, intensifies the magnetic field and hence increases the sensitivity of the galvanometer.

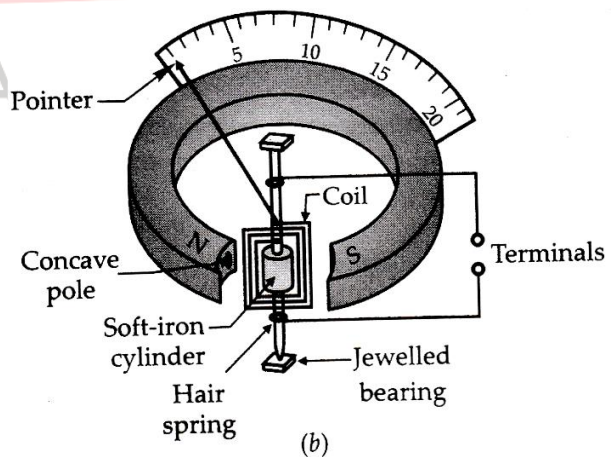

Theory and working:- In figure (a) have

I = current flowing through the coil PQRS

a, b = sides of the rectangular coil PQRS

$A = ab$ = area of the coil

N = number of turns in the coil

Since the field is radial, the plane of the coil always remains parallel to the field \vec{B} .

The magnetic forces on sides PQ and SR are equal, opposite, and collinear, so their resultant is zero. According to Fleming's left rule, the side PS experiences a normal inward force equal to $NIBB$ while the side QR experiences an equal normal outward force. The two forces on sides PS and QR are equal and opposite. They form a couple and exert a torque given by.

τ = Force \times perpendicular distance

$$= NIBB \times a \sin 90^\circ = NIB(ab) = NIBA$$

Here $\theta = 90^\circ$, because the normal to the plane of the coil remains perpendicular to the field \vec{B} in all positions.

The torque τ deflects the coil through an angle α . A restoring torque is set up in the coil due to the elasticity of the springs such that

$$\tau_{restoring} \propto \alpha \quad \text{or} \quad \tau_{restoring} = k\alpha$$

Where k is the torsion constant of the springs i.e torque required to produce unit angular twist. In equilibrium position,

$$\text{Restoring torque} = \text{Deflecting torque} \quad k\alpha = NIBA$$

$$\text{Or } \alpha = \frac{NBA}{k} I$$

$$\text{Or } \alpha \propto I$$

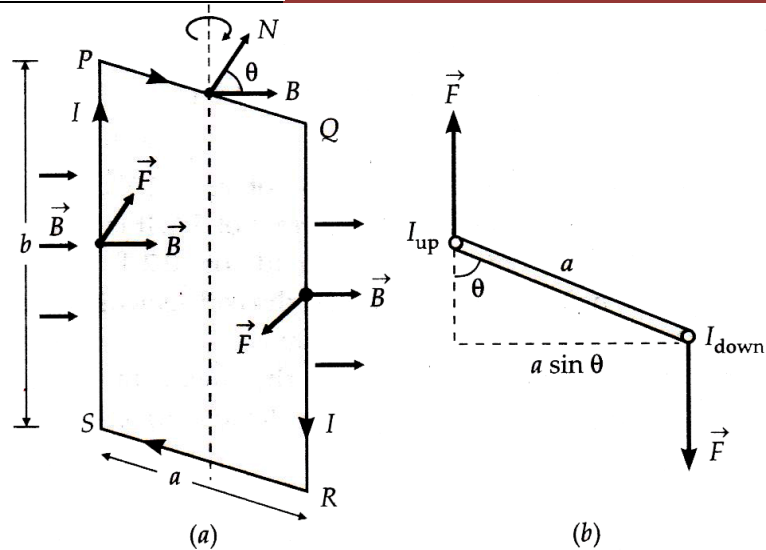

Thus, the deflection produced in the galvanometer coil is proportional to the current flowing through it. Consequently, the instrument can be provided with a scale with equal divisions along a circular scale to indicate equal steps in the current. Such a scale is called a linear scale.

$$\text{Also, } I = \frac{k}{NBA} \cdot \alpha = G\alpha$$

The factor $G = k / NBA$ is constant for a galvanometer and is called the **galvanometer constant or current reduction factor of the galvanometer**.

The figure of merit of the galvanometer. It is defined as the current which produces a deflecting of one scale division in the galvanometer and is given by.

$$G = \frac{I}{\alpha} = \frac{k}{NBA}$$

The sensitivity of a Galvanometer:-

A galvanometer is said to be sensitive if it shows large scale deflection even when a small current is passed through it or a small voltage is applied across it.

Current sensitivity:-

It is defined as the deflection produced in the galvanometer when a unit current flows through it.

$$\text{Current sensitivity, } I_s = \frac{\alpha}{I} = \frac{NBA}{k}$$

Voltage sensitivity:-

It is defined as the deflection produced in the galvanometer when a unit potential difference is applied across its ends.

$$\text{Voltage sensitivity, } V_s = \frac{\alpha}{V} = \frac{\alpha}{IR} = \frac{NBA}{kR}$$

$$\text{Clearly, } \text{voltage sensitivity} = \frac{\text{current sensitivity}}{R}$$

Factors on which the sensitivity of a moving coil galvanometer depends:-

- (a) Number of turns N in its coil (b) Magnetic field B
- (c) Area A of the coil (d) Torsion constant k of the spring and suspension wire

Factors by which the sensitivity of a moving coil galvanometer can be increased:-

- By increasing the number of turns N of the coil. But the value of N cannot be increased beyond a certain limit because that will make the galvanometer bulky and increase its resistance R .
- By increasing the magnetic field B . This can be done by using a strong horseshoe magnet and placing a soft iron core within the coil
- By increasing the area A of the coil. However, increasing A beyond a certain limit will make the galvanometer bulky and unmanageable.
- By decreasing the value of torsion constant k . The torsion constant k is made small by using suspension wire and springs of phosphor bronze.

Advantages of a moving coil galvanometer:-

- As the deflection of the coil is proportional to the current passed through it, so a linear scale can be used to measure the deflection.
- A moving coil galvanometer can be made highly sensitive by increasing N , B , A , and decreasing k .
- As the coil is placed in a strong magnetic field of a powerful magnet, its deflection is not affected by external magnetic fields. This enables us to use the galvanometer in any position.
- As the coil is wound over a metallic frame, the eddy currents produced in the frame bring the coil to rest quickly.

Disadvantages of a moving coil galvanometer:-

- The main disadvantage is that its sensitiveness cannot be changed at will
- All types of moving coil galvanometers are easily damaged by overloading. A current greater than that which the instrument is intended to measure will burn out its hairsprings or suspension.

Example:- A rectangular coil of the area $5.0 \times 10^{-4} \text{ m}^2$ and 60 turns is pivoted about one of its vertical sides. The coil is in a radial horizontal field of 90G (radial here means the field lines are in the plane of the coil for any orientation). What is the torsional constant of the hairsprings connected to the coil if a current of 0.20 mA produces an angular deflection of 18° ?

Solution:- $B = 90G = 90 \times 10^{-4} T$, $A = 5.0 \times 10^{-4} m^2$, $I = 0.20mA = 0.20 \times 10^{-3} A$, $N = 60$, $\alpha = 18^\circ$

The torsional constant of the hairspring is given by $k = \frac{NIBA}{\alpha}$

$$= \frac{60 \times 0.2 \times 10^{-3} \times 90 \times 10^{-4} \times 5 \times 10^{-4}}{18} Nm deg^{-1} = 3.0 \times 10^{-9} Nm deg^{-1}$$

Example: - A rectangular coil having each turn of length 5cm and breadth 2 cm is suspended freely in a radial magnetic field of induction $2.5 \times 10^{-2} Wbm^{-2}$, the torsional constant of the suspension fiber is $1.5 \times 10^{-8} Nmrad^{-1}$. The coil deflects through an angle of 0.2 radian when a current of $2\mu A$ is passed through it. Find the number of turns of the coil.

Solution: - $A = 5cm \times 2cm = 10 \times 10^{-4} m^2 = 10^{-3} m^2$

$$B = 2.5 \times 10^{-2} Wbm^{-2}, k = 1.5 \times 10^{-8} Nmrad^{-1}$$

$$\theta = 0.2 rad, I = 2\mu A = 2 \times 10^{-6} A$$

$$\text{As } I = \frac{k}{NBA} \cdot \alpha \quad N = \frac{k}{IBA} \cdot \alpha = \frac{1.5 \times 10^{-8} \times 0.2}{2 \times 10^{-6} \times 2.5 \times 10^{-2} \times 10^{-3}} = 60$$

Problems for Practice:-

- A rectangular coil of area $100 cm^2$ and consisting of 100 turns is suspended in a magnetic field of $5 \times 10^{-2} T$. What current should be made to pass through it in order to keep equilibrium at an angle of 45° with the field? Given that torsion constant of the suspension fiber is $10^{-8} Nm deg^{-1}$
- The coil of the galvanometer consists of 250 turns of fine wire wound on a $2.0cm \times 1.0cm$ rectangular frame. It is suspended in a uniform radial magnetic field of strength 2,000 G. A current of $10^{-4} A$ produces an angular deflection of 30° in the coil. Find the torsional constant of its suspension.
- A moving coil galvanometer is placed in a radial magnetic field of 0.2 T. The galvanometer coil has 200 turns and an area of $1.6 \times 10^{-4} m^2$. The torsion constant of the suspension fiber is $10^{-6} Nm deg^{-1}$. Determine the maximum current that can be measured by the galvanometer if its scale can accommodate a deflection of 45° .

- The coil of the moving coil galvanometer is 40 mm long and 25 mm wide. It has 100 turns and is suspended in a radial magnetic field of 10^{-2} T. If the suspension fiber has a torsional constant of 10^{-8} Nm deg $^{-1}$, find the current sensitivity of the moving coil galvanometer.
- A coil of a moving coil galvanometer twists through 45° when a current of 1 micro-ampere is passed through it. If the area of the coil is 10^{-5} m 2 and it has 1000 turns, find the magnetic field of the magnet of the galvanometer. The restoring torque per unit twist of the galvanometer coil is 10^{-4} Nm deg $^{-1}$.
- The coil of a pivoted type galvanometer has 50 turns and encloses an area of 6 m 2 . The magnetic field in the region in which the coil swings is 0.01 T and is radial. The torsional constant of the hairspring is 1.0×10^{-8} Nm deg $^{-1}$. Find the angular deflection of the coil for a current of 1 mA.

Measurement of Current and Voltage:-

Introduction: - A galvanometer is a basic instrument for electrical measurements. It is a sensitive current detector. It produces a deflection proportional to the current flowing through it. It can be easily converted into an ammeter for measuring current and into a voltmeter for measuring voltage.

The following essential requirements should be met while converting a galvanometer into an ammeter or voltmeter.

- The ammeter or voltmeter should be accurate, reliable, and sensitive.
- The use of these devices in a circuit must not alter the current in the circuit or the potential difference across any element in the circuit.

Conversion of a Galvanometer into an Ammeter:-

An ammeter is a device used to measure the current through a circuit element. To measure the current through a circuit element, an ammeter is connected in series with that element so that the current which is to be measured actually passes through it. In order to ensure that its insertion in the circuit does not change the

current, an ammeter should have zero resistance. So ammeter is designed to have very small effective resistance. In fact, an ideal ammeter should have zero resistance. An ordinary galvanometer is a sensitive instrument. It gives full-scale deflection with a small current of few microamperes. To

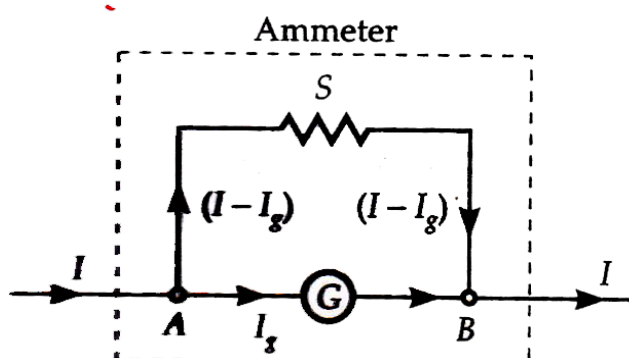

measure large currents with it, a small resistance is connected in parallel with the galvanometer coil. The resistance connected in this way is called a shunt. Only a small part of the total current passes through the galvanometer and the remaining current passes through the shunt. The value of shunt resistance depends on the range of the current required to be measured.

Let G = resistance of the galvanometer

I_g = the current with which galvanometer gives a full-scale deflection

$0 - I$ = the required current range of the ammeter

S = shunt resistance

$I - I_g$ = current through the shunt.

As galvanometer and shunt are connected in parallel, so P.D across the galvanometer = P.D across the shunt $I_g G = (I - I_g) S$

$$\text{Or } S = \frac{I_g}{I - I_g} \times G$$

So by connecting a shunt of resistance S across the given galvanometer, we get an ammeter of the desired range. Moreover,

$$I_g = \frac{S}{G + S} \times I$$

The deflection in the galvanometer is proportional to I_g and hence to I . so the scale can be graduated to read the value of current I directly.

Hence an ammeter is a shunted or low resistance galvanometer. Its effective resistance is.

$$R_A = \frac{GS}{G + S} < S$$

What is a shunt? Mention its importance uses.

Shunt:- A shunt is a low resistance that is connected in parallel with a galvanometer (or ammeter) to protect it from strong currents.

Uses of shunt:-

- To prevent a galvanometer from being damaged due to large current.
- To convert a galvanometer into ammeter
- To increase the range of an ammeter.

Conversion of a Galvanometer into a Voltmeter: -

A voltmeter is a device for measuring potential difference across any two points in a circuit. It is connected in parallel with the circuit element across which the potential difference is intended to be measured. As a result, a small part of the total current passes

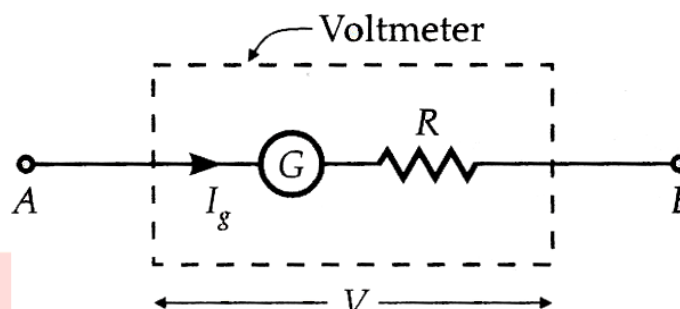

through the voltmeter and so the current through the circuit element decreases. This decreases the potential difference required to be measured. To avoid this, the voltmeter should be designed to have very high resistance. In fact, an ideal voltmeter should have infinite resistance.

A galvanometer can be converted into a voltmeter by connecting a high resistance in series with it. The value of this resistance is so adjusted that only current I_g which produces full-scale deflection in the galvanometer passes through the galvanometer.

Let G = resistance of the galvanometer

I_g = the current with which galvanometer gives a full-scale deflection

$0 - V$ = required range of the voltmeter,

R = the high series resistance which restricts the current to the safe limit I_g

The total resistance in the circuit = $R + G$

By Ohm's law

$$I_g = \frac{\text{Potential difference}}{\text{Total resistance}} = \frac{V}{R + G}$$

$$\text{Or } \mathbf{R + G = \frac{V}{I_g} \text{ or } R = \frac{V}{I_g} - G}$$

So by connecting a high resistance R in series with the galvanometer, we get a voltmeter of the desired range. Moreover, the deflection in the galvanometer is proportional to current I_g , and hence to V . The scale can be graduated to read the value of potential difference directly. Hence a voltmeter is a high resistance galvanometer. Its effective resistance is $R_v = R + G \gg G$

Example: -

A galvanometer with a coil of resistance 12.0Ω shows full-scale deflection for a current 2.5 mA . How will you convert the meter into (a) an ammeter of range 0 to 7.5 A (b) a voltmeter of range 0 to 10.0 V ? Determine the net resistance of the meter in each case. When an ammeter is put in a circuit, does it read (slightly) less or more than the actual current in the original circuit? When a voltmeter is put across a part of the circuit, does it read (slightly) less or more than the original voltage drop? Explain.

Solution: -

(a) for conversion into the ammeter

$$R_g = 12\Omega, I_g = 2.5\text{mA} = 0.0025\text{A}, I = 7.5\text{A}$$

$$R_s = \frac{I_g}{I - I_g} \times R_g = \frac{0.0025}{7.5 - 0.0025} \times 12$$

$$= \frac{2.5 \times 12 \times 10^{-3}}{7.4975} = 4.0 \times 10^{-3} \Omega$$

So, by connecting a shunt resistance of $4.0 \times 10^{-3} \Omega$ in parallel with the galvanometer, we get an ammeter of range 0 to 7.5 A .

Net resistance R_A is given by

$$\frac{1}{R_A} = \frac{1}{12} + \frac{1}{4 \times 10^{-3}} = \frac{3001}{12}$$

$$\text{Or } R_A = \frac{12}{3001} \Omega = 4 \times 10^{-3} \Omega$$

When an ammeter is put in a circuit, it reads slightly less than the actual current in the original circuit because a very small resistance is introduced in the circuit.

(b) For conversion into voltmeter

$$R_g = 12 \Omega, I_g = 2.5 \times 10^{-3} \text{ A}, V = 10 \text{ V}$$

$$R = \frac{V}{I_g} - R_g = \frac{10}{2.5 \times 10^{-3}} - 12 = 4000 - 12 = 3988 \Omega$$

So, by connecting a resistance of 3988Ω in series with the galvanometer, we get a voltmeter of range 0 to 10v. Net resistance, $R_v = (3988 + 12) \Omega = 4000 \Omega$

Because the voltmeter draws a small current for its deflection, so it reads slightly less than the original voltage drops.

Example: - An ammeter of resistance 0.80Ω can measure currents up to 1.0 A (a) what must be the shunt resistance to enable the ammeter to measure current up to 5.0 A ? (b) what is the combined resistance of the ammeter and the shunt?

Solution:-

The given ammeter can be regarded as the galvanometer. $I_g = 1.0 \text{ A}, R_g = 0.80 \Omega$

(a) The total current in the circuit, $I = 5.0 \text{ A}$

The required shunt resistance,

$$R_s = \frac{I_g}{I - I_g} \times R_g = \frac{1.0}{5.0 - 1.0} \times 0.80 = 0.20 \Omega$$

(b) The combined resistance R_A of the ammeter and the shunt is given by

$$\frac{1}{R_A} = \frac{1}{R_g} + \frac{1}{R_s} = \frac{1}{0.8} + \frac{1}{0.2} = \frac{1+4}{0.8} = \frac{25}{4}$$

$$\text{Or } R_A = 4/25 = 0.16 \Omega$$