

**SESSION : 7**

**CLASS : 3**

**SUBJECT : MATHEMATICS**

**CHAPTER NUMBER: 2**

**CHAPTER NAME :NUMBERS**

**SUBTOPIC : EXPANDED NOTATION, EXPANDED FORM, COMPACT FORM**

---

**CHANGING YOUR TOMORROW**

---

## **LEARNING OBJECTIVE :**

**They will be able to:**

- \* Identify the digit in ones, tens, hundred, thousand and ten thousand place.**
- \* Write a 5-digit number in expanded notation.**
- \* Expand a 5-digit number according to the place value of each digit.**
- \* Construct a number when digits of different places are said.**

# Expanded Form

Children you have already learnt how to write a 5-digit number in a place value chart in previous classes.

Example: take the number 13526

TTh	Th	H	T	O
1	3	5	2	6

So, it is thirteen thousand five hundred twenty six.

# NUMBERS

## EXPANDED NOTATION, EXPANDED FORM, COMPACT FORM

let us now compare two, 5-digit numbers

1<sup>st</sup> number – 2 3 7 9 8

2<sup>nd</sup> number – 8 7 9 3 2

let us see the place value of both the numbers →



C  
O  
M  
P  
A  
R  
E



# NUMBERS

## EXPANDED NOTATION, EXPANDED FORM, COMPACT FORM

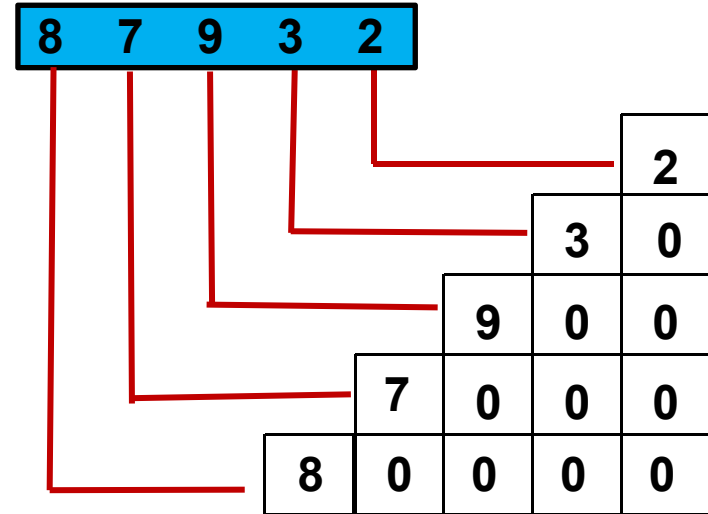
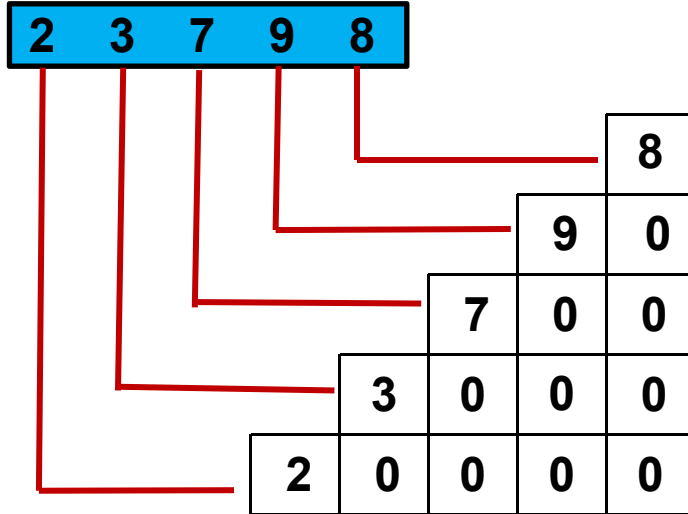

# NUMBERS

EXPANDED NOTATION, EXPANDED FORM, COMPACT FORM

**The digits have different Place Values in the two different numbers because they are in different places.**

# NUMBERS

## EXPANDED NOTATION, EXPANDED FORM, COMPACT FORM

THE DIGITS ARE:

3, 5, 1, 8, 9

NOW LET US TAKE FEW DIGITS

LET US MAKE THREE 5-DIGITS NUMBERS

TTh	Th	H	T	O
1	3	5	8	9
5	9	8	1	3
9	8	1	3	5



# NUMBERS

## EXPANDED NOTATION, EXPANDED FORM, COMPACT FORM

### EXPANDED FORM

From this we can say that a number when expressed as a sum of place values of different digits it is said to be in expanded form .



# NUMBERS

## EXPANDED NOTATION, EXPANDED FORM, COMPACT FORM

### 1st Number

$$13589 = 10000 + 3000 + 500 + 80 + 9$$

### 2nd Number

$$59813 = 50000 + 9000 + 800 + 10 + 3$$

### 3rd Number

$$98135 = 90000 + 8000 + 100 + 30 + 5$$

# NUMBERS

## EXPANDED NOTATION, EXPANDED FORM, COMPACT FORM

### COMPACT FORM

When we write a number using digits seeing the expanded form is called short form or Compact form. It is also called standard form of a number.

# NUMBERS

## EXPANDED NOTATION, EXPANDED FORM, COMPACT FORM

Let us see examples:

$$70000 + 3000 + 900 + 40 + 2 = 73942$$

$$30000 + 8000 + 200 + 60 + 4 = 38264$$

# NUMBERS

## EXPANDED NOTATION, EXPANDED FORM, COMPACT FORM

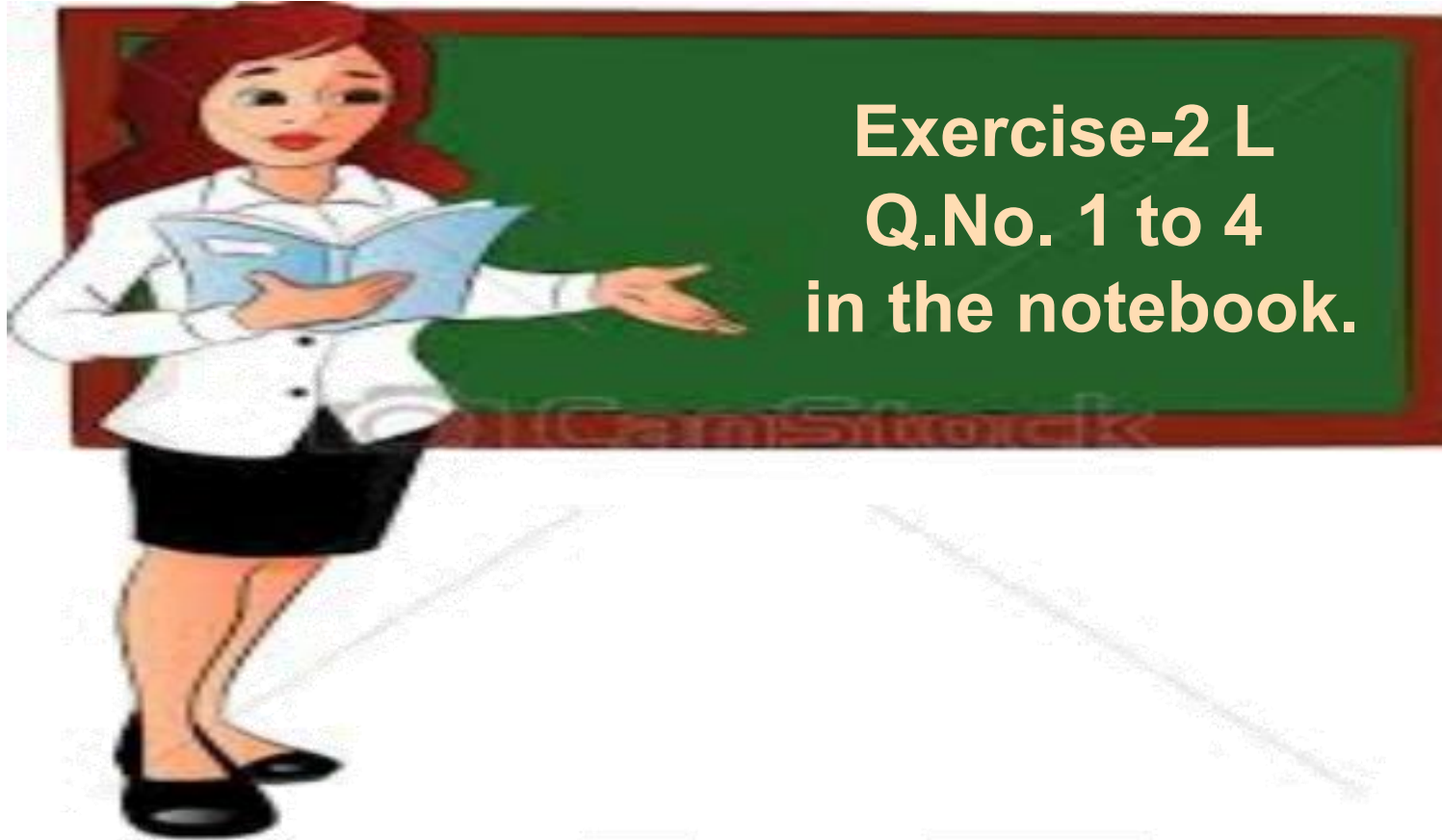

# NUMBERS

## EXPANDED NOTATION, EXPANDED FORM, COMPACT FORM

Write each number in expanded notation.

1)  $17814 =$  1 ten thousand 7 thousands  
8 hundreds 1 tens 4 ones

2)  $24836 =$  2 ten thousands 4 thousands  
8 hundreds 3 tens 6 ones

# NUMBERS

## EXPANDED NOTATION, EXPANDED FORM, COMPACT FORM

3)  $37942 =$  3 **ten thousands** 7 **thousands**  
9 **hundreds** 4 **tens** 2 **ones**

4)  $72043 =$  7 **ten thousands** 2 **thousands**  
0 **hundreds** 4 **tens** 3 **ones**

# NUMBERS

## EXPANDED NOTATION, EXPANDED FORM, COMPACT FORM

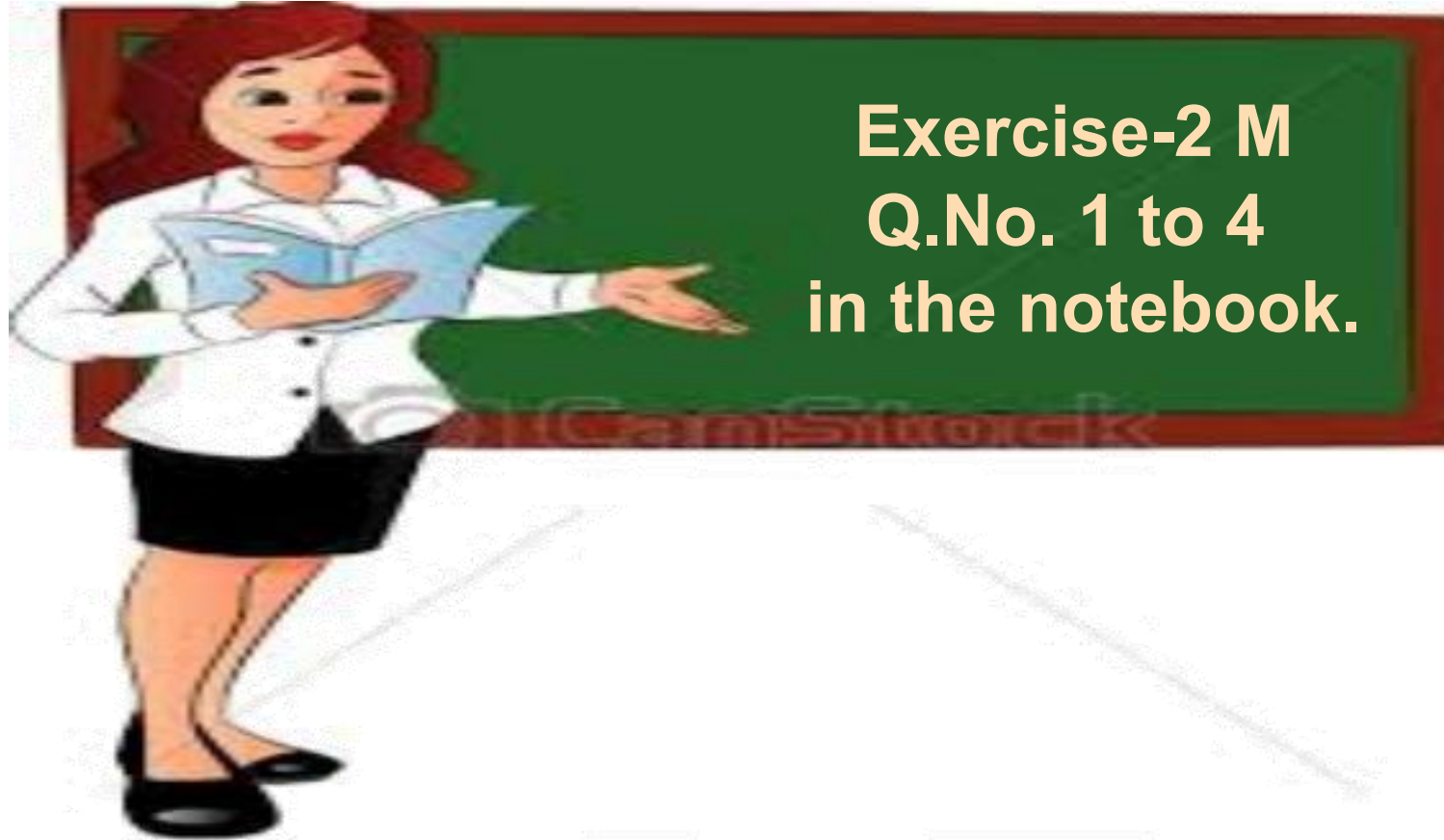

# NUMBERS

## EXPANDED NOTATION, EXPANDED FORM, COMPACT FORM

Write the expanded form of each of the following :

1  $58924 = 50000 + 8000 + 900 + 20 + 4$

2  $89075 = 80000 + 9000 + 0 + 70 + 5$

3  $71007 = 70000 + 1000 + 0 + 0 + 7$

4  $95570 = 90000 + 5000 + 500 + 70 + 0$



# NUMBERS

## EXPANDED NOTATION, EXPANDED FORM, COMPACT FORM

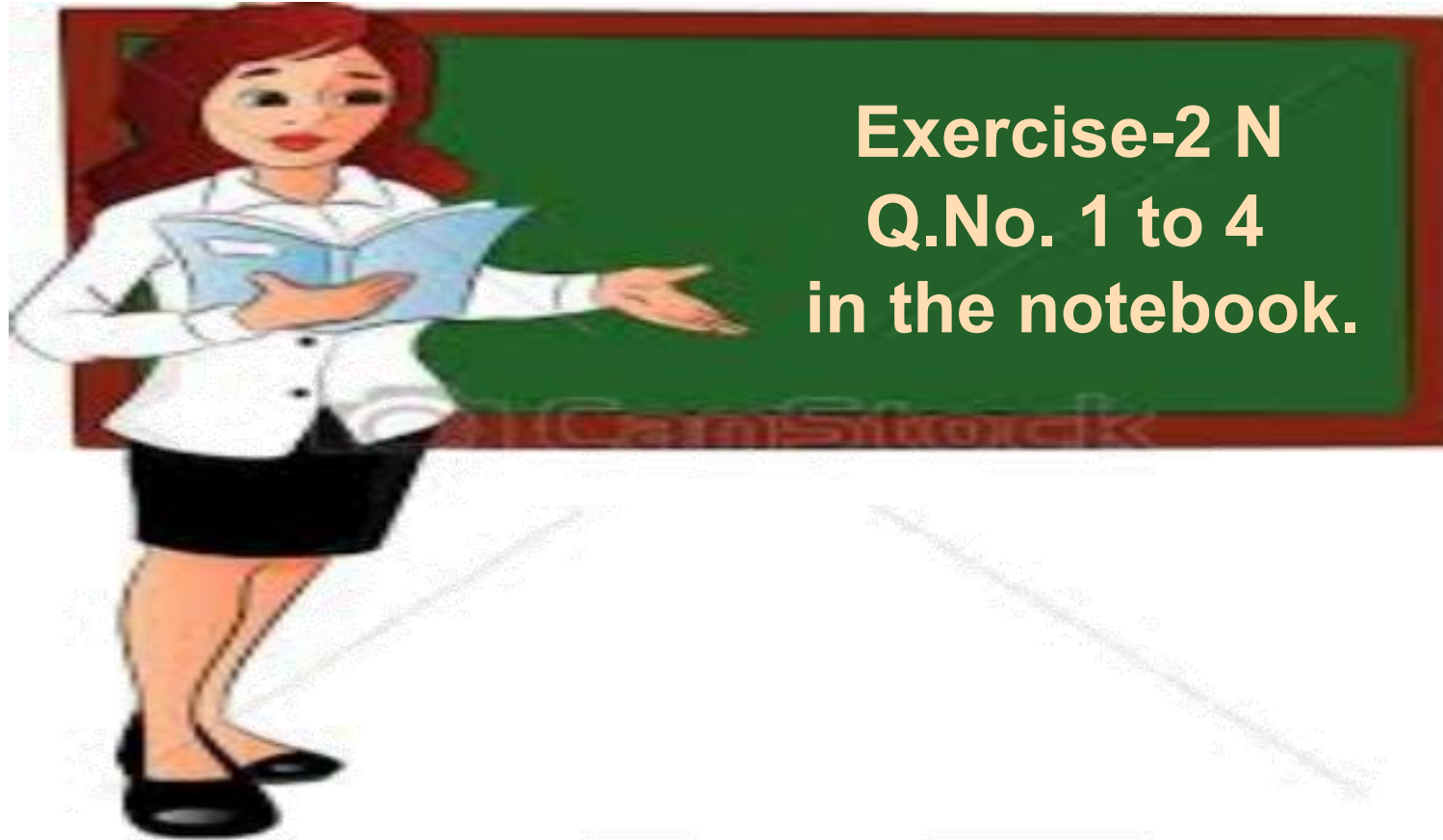

# NUMBERS

## EXPANDED NOTATION, EXPANDED FORM, COMPACT FORM

Express in compact form

1  $10000 + 7000 + 500 + 0 + 4 = 17504$

2  $40000 + 0 + 700 + 80 + 6 = 40786$

3  $60000 + 1000 + 100 + 10 + 1 = 61111$

4  $10000 + 4000 + 0 + 0 + 4 = 14004$

# NUMBERS

## EXPANDED NOTATION, EXPANDED FORM, COMPACT FORM

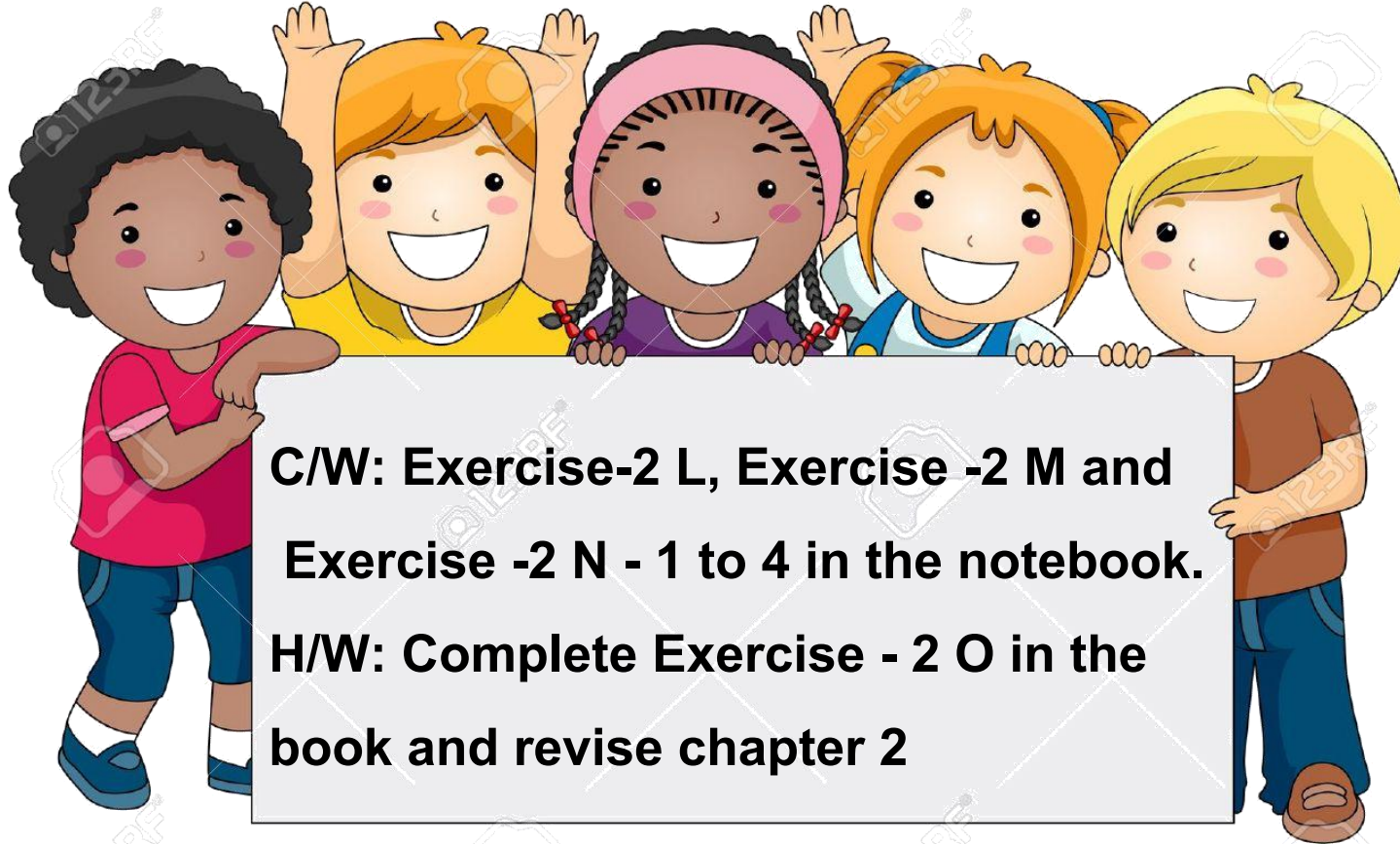

**C/W: Exercise-2 L, Exercise -2 M and  
Exercise -2 N - 1 to 4 in the notebook.**

**H/W: Complete Exercise - 2 O in the  
book and revise chapter 2**

## **LEARNING OUTCOME:**

**Children are confident to find different digits of a 4-digit number in different places. Also can write a 4-digit number in expanded notation, expanded form with correct place values and compact form.**



**THANKING YOU**  
**ODM EDUCATIONAL GROUP**