

SESSION : 6

CLASS : 3

SUBJECT : MATHEMATICS

CHAPTER NUMBER: 8

CHAPTER NAME : MEASUREMENT

**SUBTOPIC : MULTIPLICATION TABLE -17 AND 18, DOUBT CLEARING AND
CLASS TEST**

CHANGING YOUR TOMORROW

MEASUREMENT

MULTIPLICATION TABLES 17 and 18

**Multiplication tables-17 and 18
in notebook.**



MULTIPLICATION TABLE - 16

$16 \times 1 =$

$16 \times 2 =$

$16 \times 3 =$

$16 \times 4 =$

$16 \times 5 =$

$16 \times 6 =$

$16 \times 7 =$

$16 \times 8 =$

$16 \times 9 =$

$16 \times 10 =$



shutterstock.com - 145483363



shutterstock.com - 1104686500

MULTIPLICATION TABLE - 16

MULTIPLICATION TABLES 16

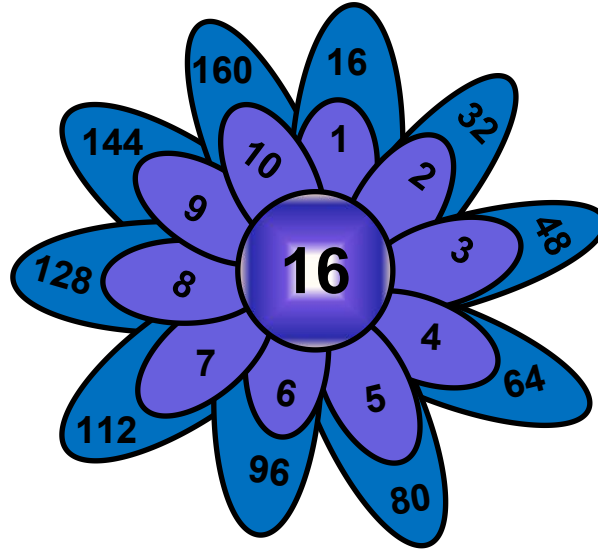

MULTIPLICATION TABLE - 17

$17 \times 1 =$

$17 \times 2 =$

$17 \times 3 =$

$17 \times 4 =$

$17 \times 5 =$

$17 \times 6 =$

$17 \times 7 =$

$17 \times 8 =$

$17 \times 9 =$

$17 \times 10 =$



shutterstock.com - 145483363



shutterstock.com - 1204686500

MEASUREMENT

DOUBT CLEARING AND CLASS TEST

**Doubt clearing and class test
in test notebook.**



MATHS

MEASUREMENT

DOUBT CLEARING AND CLASS TEST

1

Circle the suitable unit to measure each:

$$4 \times 1 = 4$$

1) A big packet of oil

(ml , l)

2) A glass of milk

(ml , l)

3) A piece of cloth

(cm , m)

4) Distance from your school to home

(km , kg)

M
H
T
H
S

MEASUREMENT

DOUBT CLEARING AND CLASS TEST

2 A) Convert the following into centimetres.

2

17 m 75 cm

B) Convert the following into metres.

2

552 cm

C) Puskar went to the market from his home which is 2 _____ away and bought 5 _____ potatoes , 1 _____ oil and 500 _____ dal and came back to his home. Can you guess the units he used for his purchase?

4

MEASUREMENT

DOUBT CLEARING AND CLASS TEST

3

Draw line segments with the given lengths.

$$3 \times 1 = 3$$

a) 6 cm 5 mm

b) 5 cm

c) 3 cm 5 mm

MEASUREMENT

DOUBT CLEARING AND CLASS TEST

ANSWERS

MEASUREMENT

DOUBT CLEARING AND CLASS TEST

1 Circle the suitable unit to measure each:

$$4 \times 1 = 4$$

1) A big packet of oil

(ml , l)

2) A glass of milk

(ml , l)

3) A piece of cloth

(cm , m)

4) Distance from your school to home

(km , kg)

MEASUREMENT

DOUBT CLEARING AND CLASS TEST

2

A) Convert the following into centimetres.

2

17 m 75 cm

$$17 \text{ m} = 17 \times 100 = 1700 \text{ cm}$$

$$17 \text{ m } 75 \text{ cm} = 1700 \text{ cm} + 75 \text{ cm} = 1775 \text{ cm}$$

B) Convert the following into metres.

2

552 cm

$$552 \div 100 = 5 \text{ m } 52 \text{ cm}$$

MEASUREMENT

DOUBT CLEARING AND CLASS TEST

C) Puskar went to the market from his home which is 2 away and bought 5 potatoes , 1 oil and 500 dal and came back to his home. Can you guess the units he used for his purchase?

MEASUREMENT

DOUBT CLEARING AND CLASS TEST

3

Draw line segments with the given lengths.

$3 \times 1 = 3$

a) 6 cm 5 mm

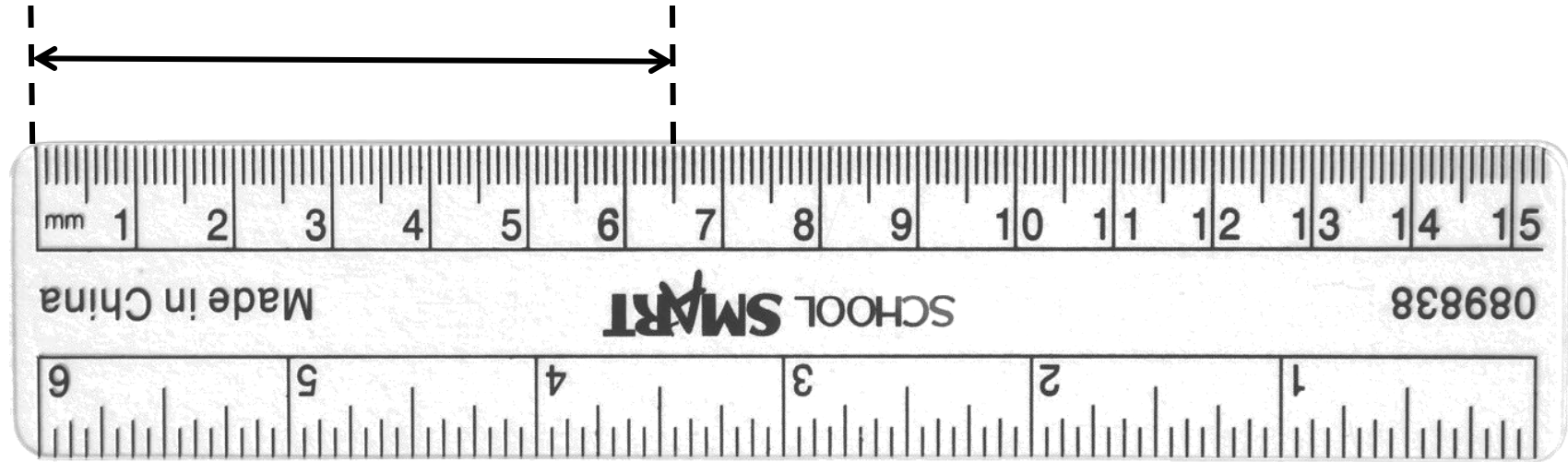

MEASUREMENT

DOUBT CLEARING AND CLASS TEST

b) 5 cm

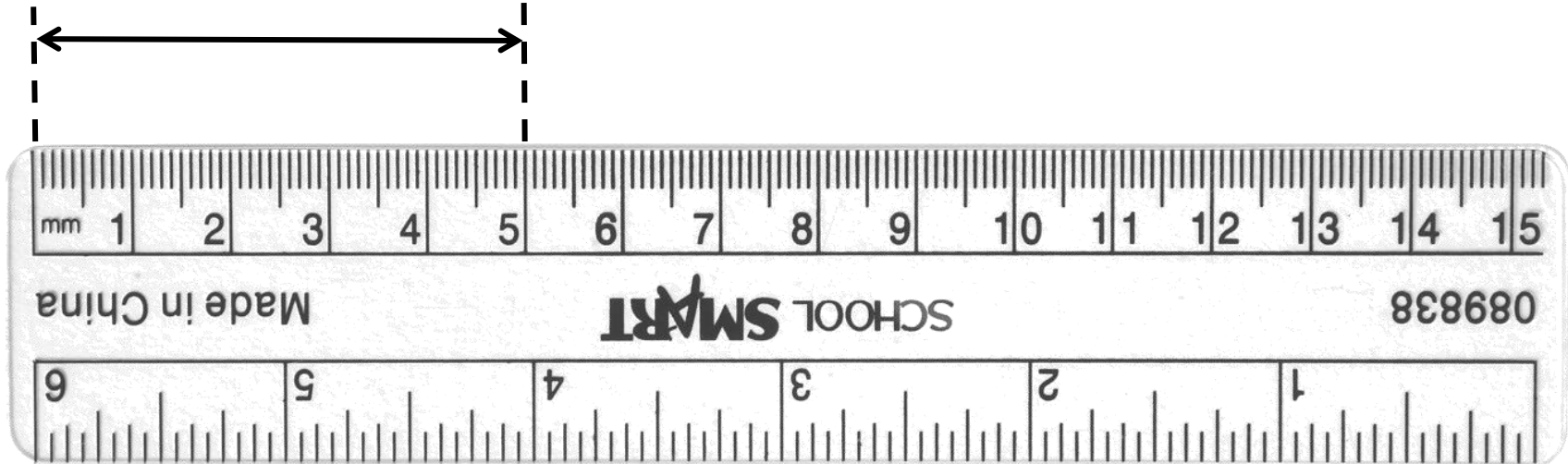

MEASUREMENT

DOUBT CLEARING AND CLASS TEST

c) 3 cm 5 mm

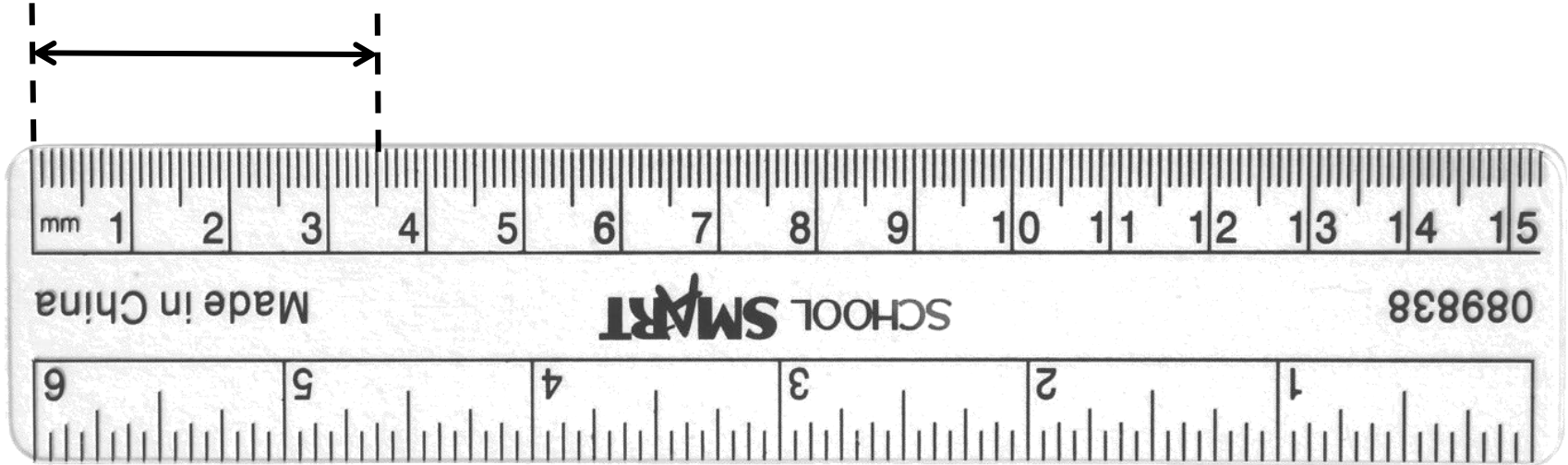

MEASUREMENT

DOUBT CLEARING AND CLASS TEST

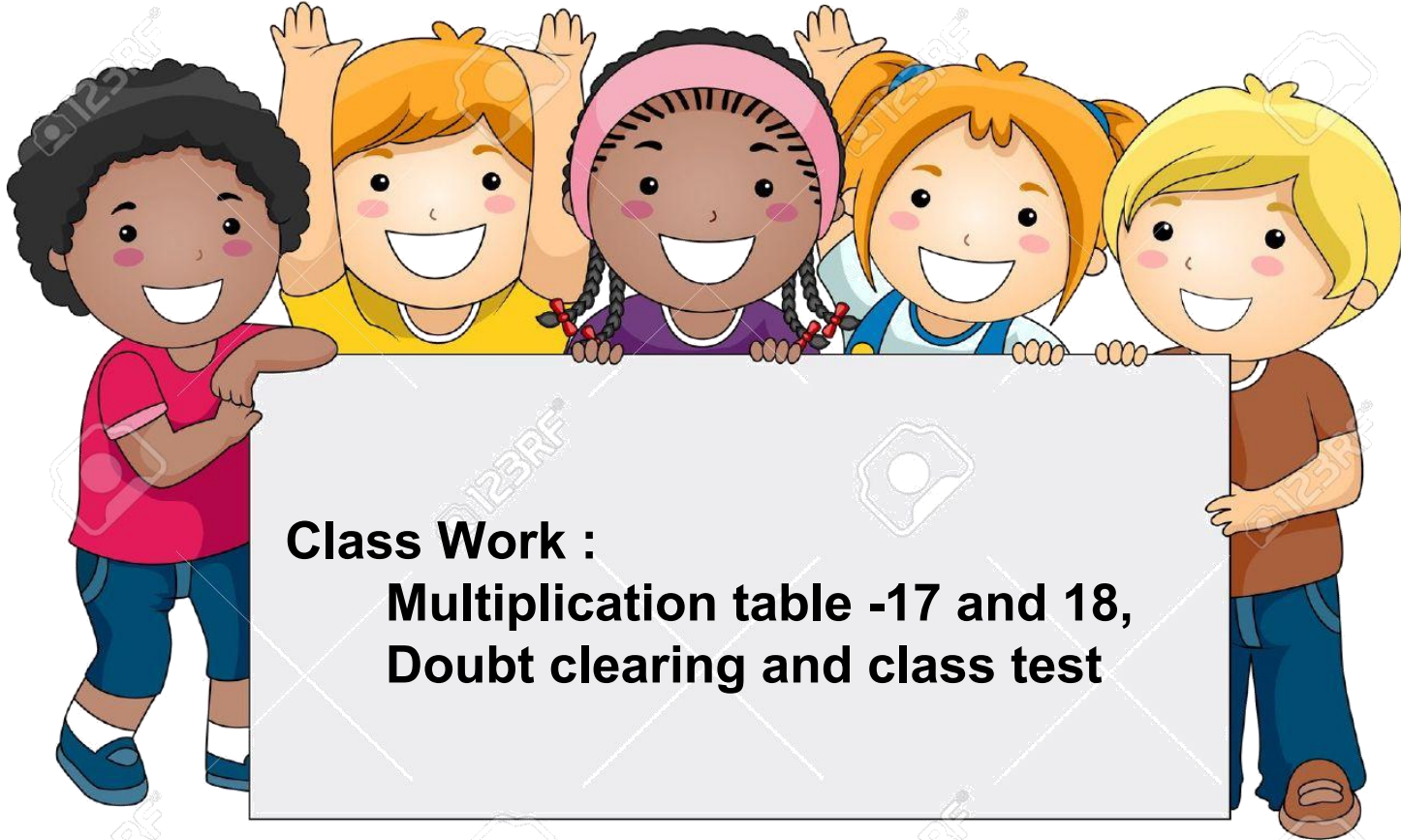

LEARNING OUTCOME:

Children are able to solve a multiplication operation using mathematical table , understand mathematical learning and tend to be more self-assured when learning new concepts.

THANKING YOU
ODM EDUCATIONAL GROUP