

SESSION : 10

CLASS : 3

SUBJECT : MATHEMATICS

CHAPTER NUMBER: 8

CHAPTER NAME : MEASUREMENT

SUBTOPIC : MEASURING AND DRAWING A LINE SEGMENT OF GIVEN LENGTH

CHANGING YOUR TOMORROW

LEARNING OBJECTIVE :

Children will

- * Differentiate between different length of a line.
- * Be able to find the length of a line segment.
- * Identify relationship.
- * Measure the length of the given line.
- * Draw a line according to the given length.

MEASUREMENT

MEASURING AND DRAWING A LINE SEGMENT OF GIVEN LENGTH

LET'S
RECAPITULATE



1. 1 meter = 100 centimetres, 1 m = 100 cm

2. 1 centimetre = 10 millimetres, 1 cm = 10 mm

3. Standard unit of length is metre.

4. Biggest unit for measuring length is kilometre.

MEASUREMENT

MEASURING AND DRAWING A LINE SEGMENT OF GIVEN LENGTH

Write m, cm or mm in the blank space:

- (i) My pen is 10 _____ long.
- (ii) The length of the pencil point is 1 _____.
- (iii) Your bedroom is 9 _____ long.
- (iv) I bought 10 _____ rope to tie the box.
- (v) My father's height is 190 _____.



MEASUREMENT

MEASURING AND DRAWING A LINE SEGMENT OF GIVEN LENGTH

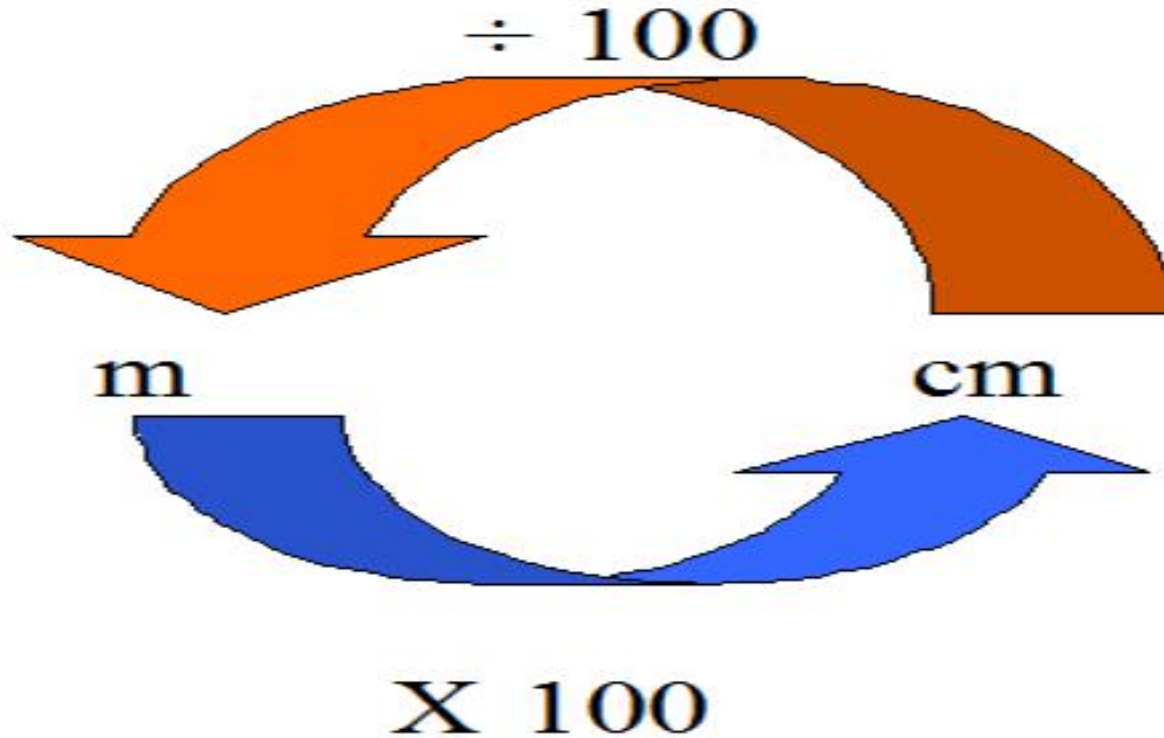

MEASUREMENT

MEASURING AND DRAWING A LINE SEGMENT OF GIVEN LENGTH

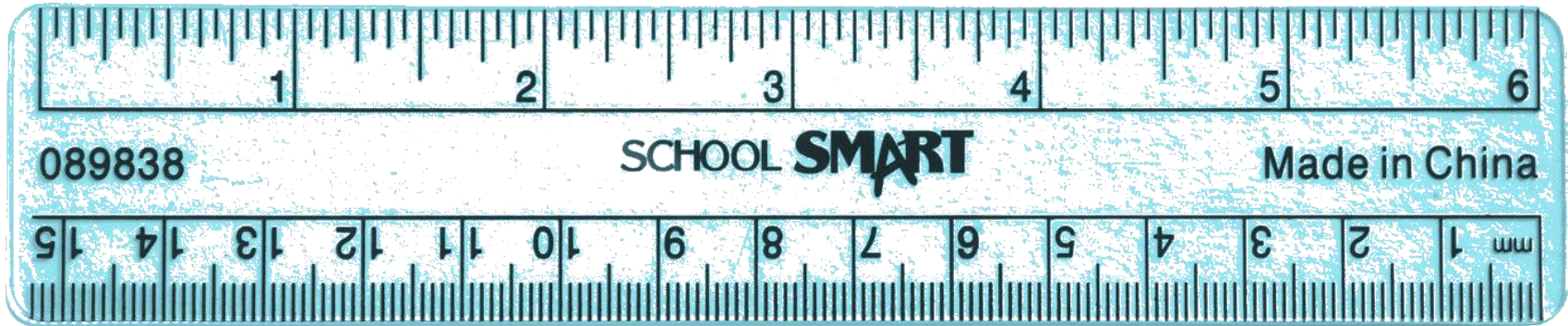

To measure the length of a given line segment we use a scale. We place the scale along the line segment. One end should be at the zero mark of the scale. The other end of the line segment where it points on the scale gives the length of the given line segment.

MEASUREMENT

MEASURING AND DRAWING A LINE SEGMENT OF GIVEN LENGTH

Let  be the given line segment.

So it is 6 cm long.

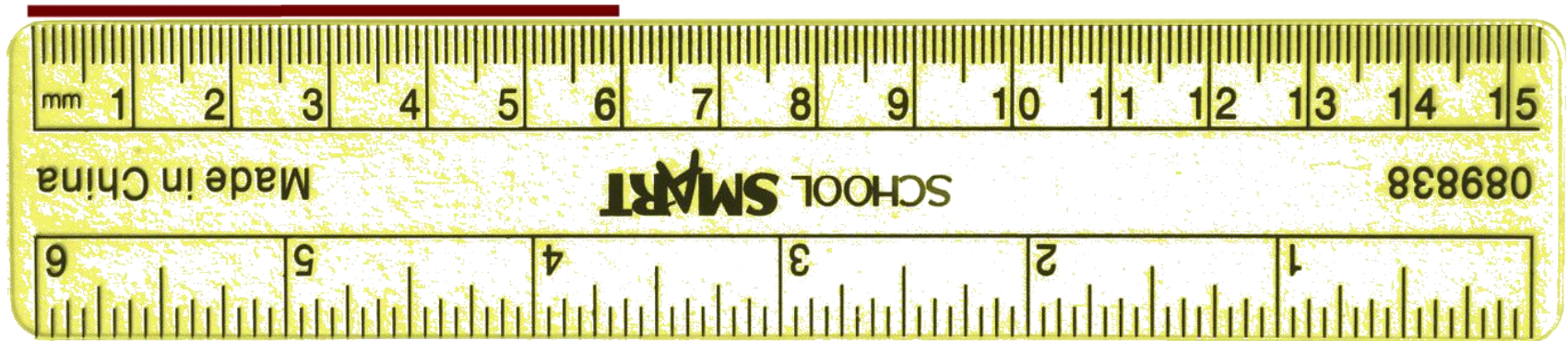

MEASUREMENT

MEASURING AND DRAWING A LINE SEGMENT OF GIVEN LENGTH

Let us learn the steps to draw a line segment.

Draw a line segment AB of 5 cm.

Step 1

Place the scale on a paper.

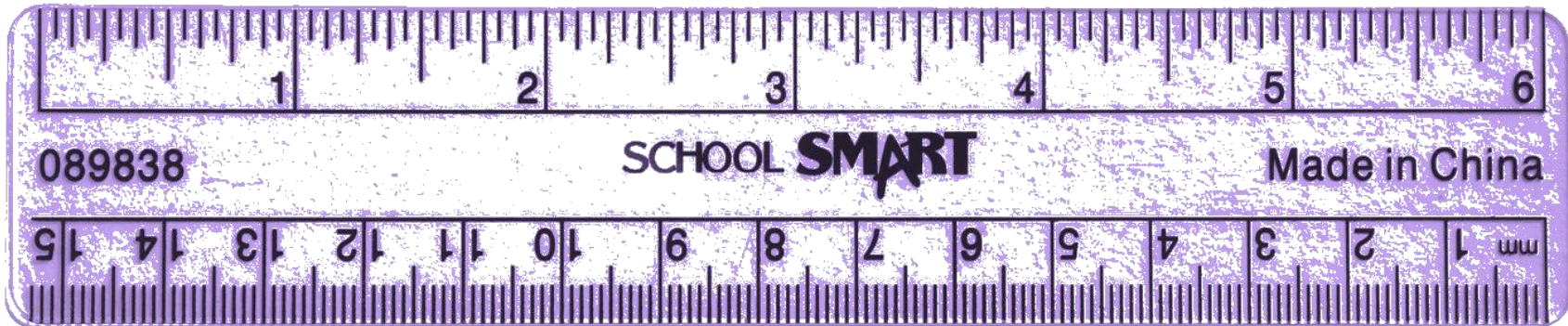

MEASUREMENT

MEASURING AND DRAWING A LINE SEGMENT OF GIVEN LENGTH

Step 2

Mark a point A at zero of the scale.

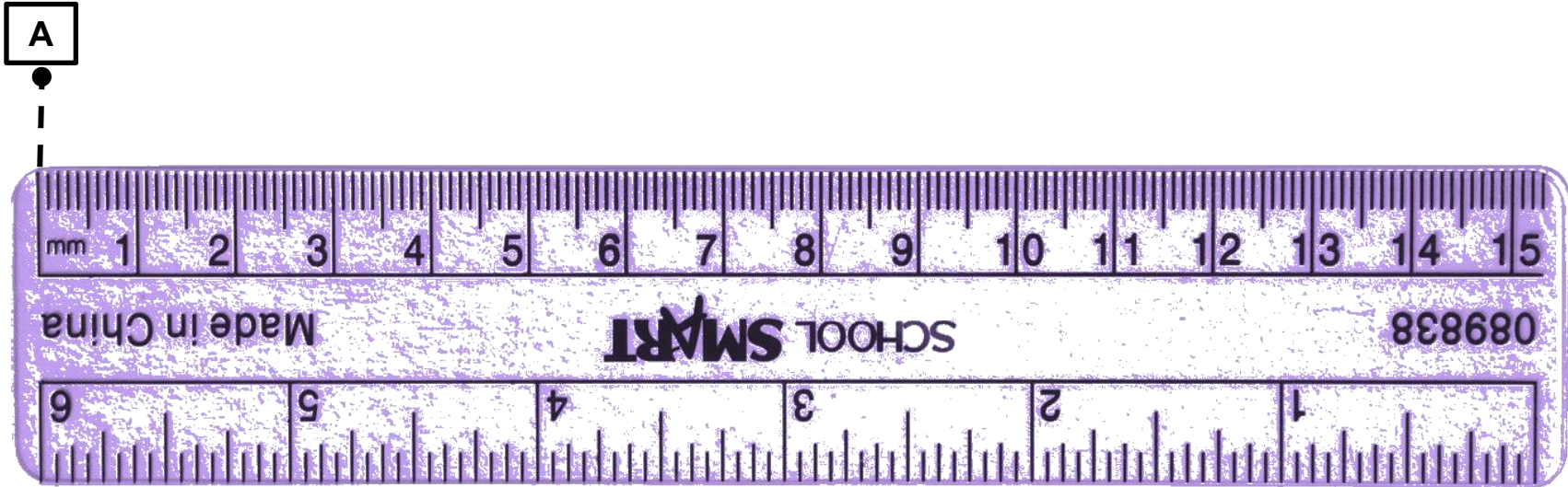

MEASUREMENT

MEASURING AND DRAWING A LINE SEGMENT OF GIVEN LENGTH

Step 3

Mark a point B at 5 of the scale.

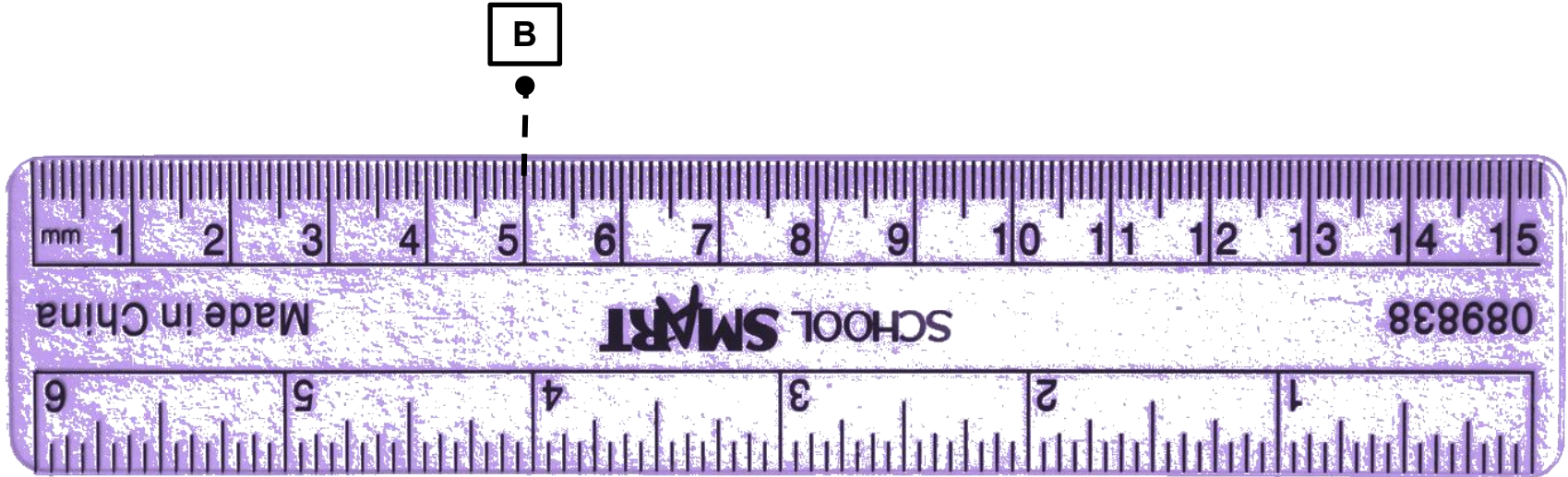

MEASUREMENT

MEASURING AND DRAWING A LINE SEGMENT OF GIVEN LENGTH

Step 4

Draw a line from A to B .

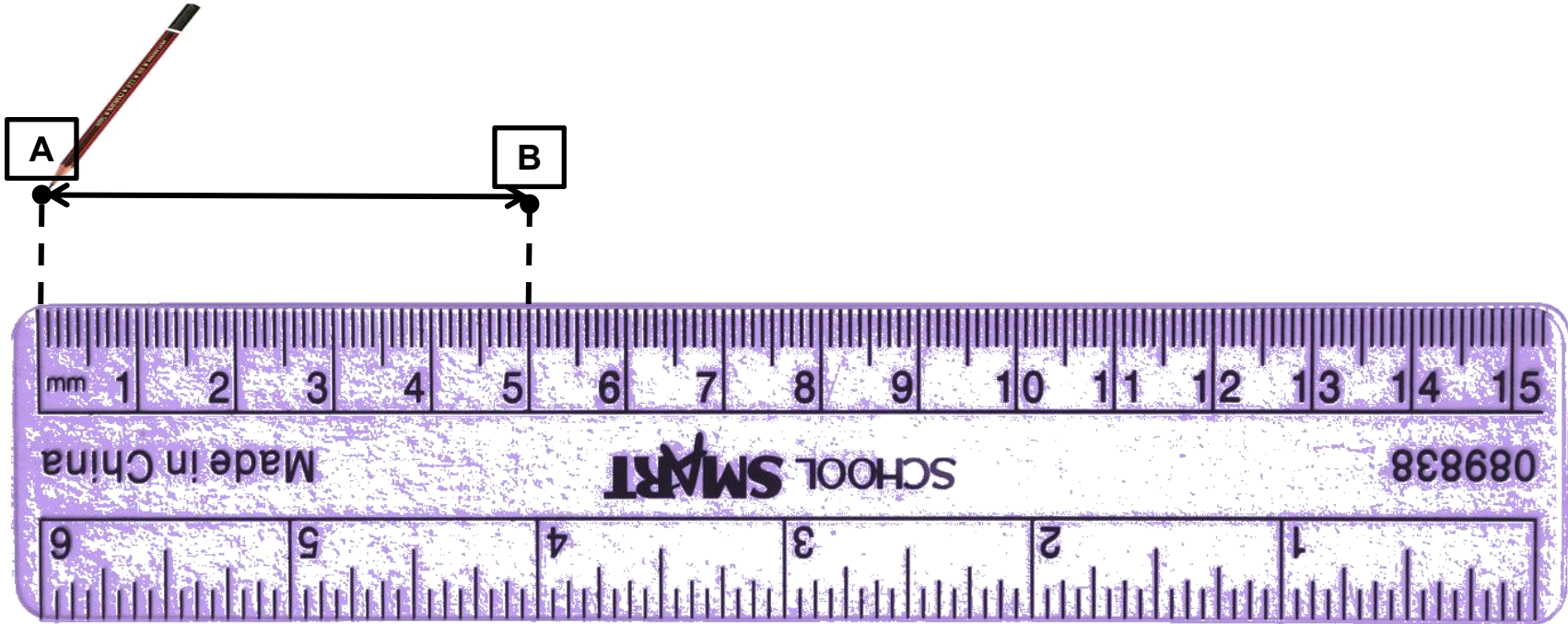

MEASUREMENT

MEASURING AND DRAWING A LINE SEGMENT OF GIVEN LENGTH

**Exercise-8 B Q.No A
book page - 107 &108
in the book.**



MEASUREMENT

MEASURING AND DRAWING A LINE SEGMENT OF GIVEN LENGTH

A. Write the length of the following line segments.

1

ANS: 5cm

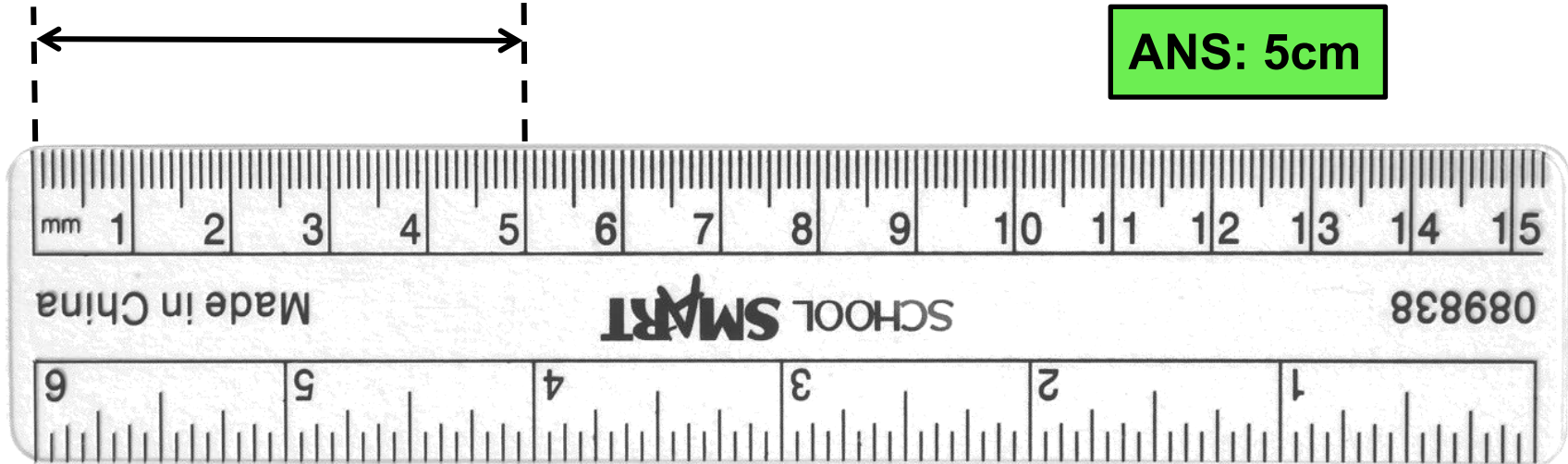

MEASUREMENT

MEASURING AND DRAWING A LINE SEGMENT OF GIVEN LENGTH

2

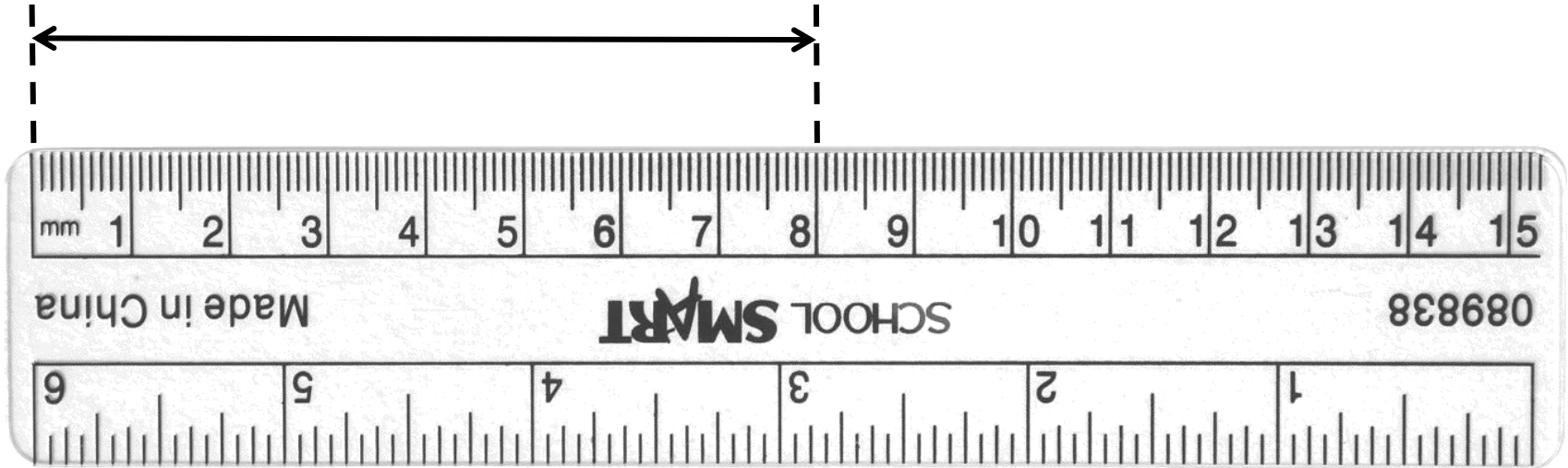

ANS: 8cm

MEASUREMENT

MEASURING AND DRAWING A LINE SEGMENT OF GIVEN LENGTH

3

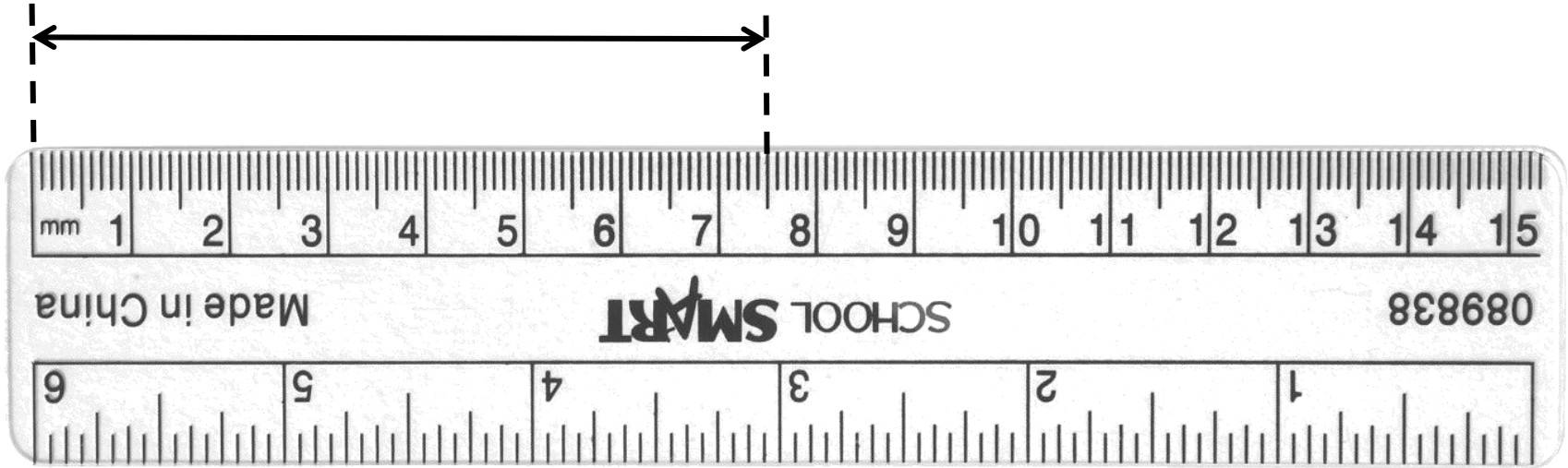

ANS: 7 cm 5 mm

MEASUREMENT

MEASURING AND DRAWING A LINE SEGMENT OF GIVEN LENGTH

4

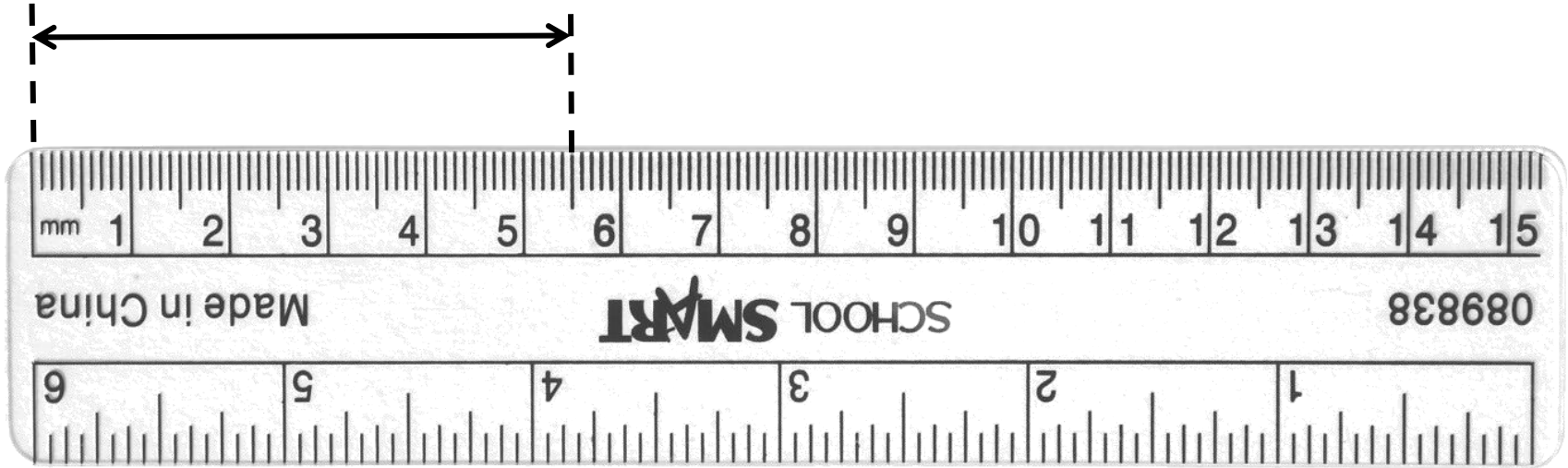

ANS: 5 cm 5 mm

MEASUREMENT

MEASURING AND DRAWING A LINE SEGMENT OF GIVEN LENGTH

5

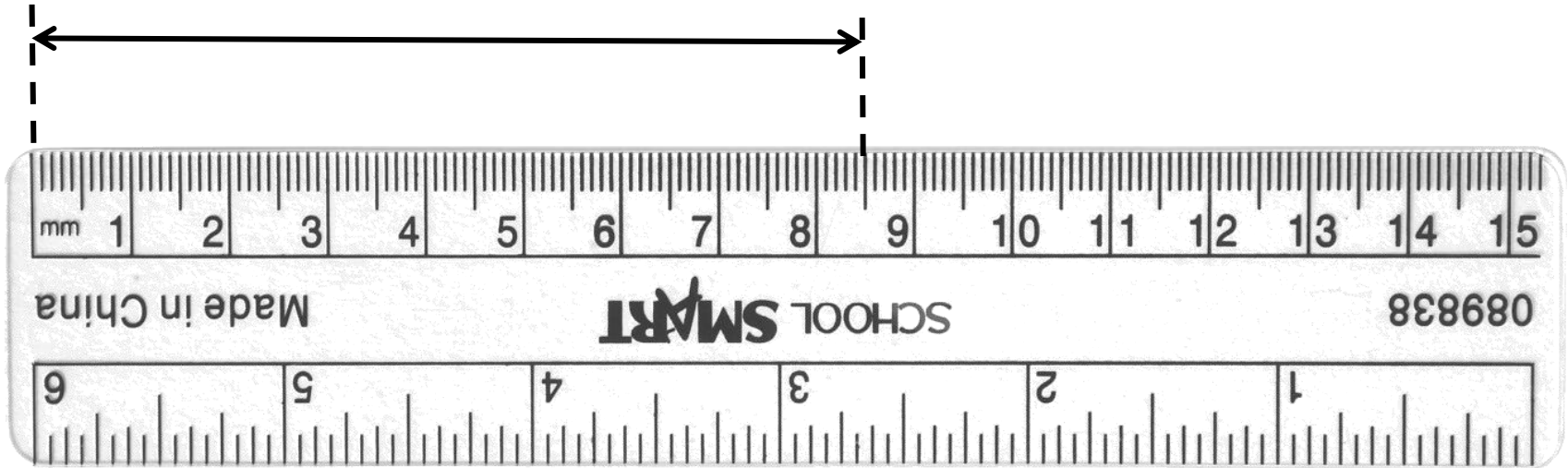

ANS: 8 cm 5 mm

MEASUREMENT

MEASURING AND DRAWING A LINE SEGMENT OF GIVEN LENGTH

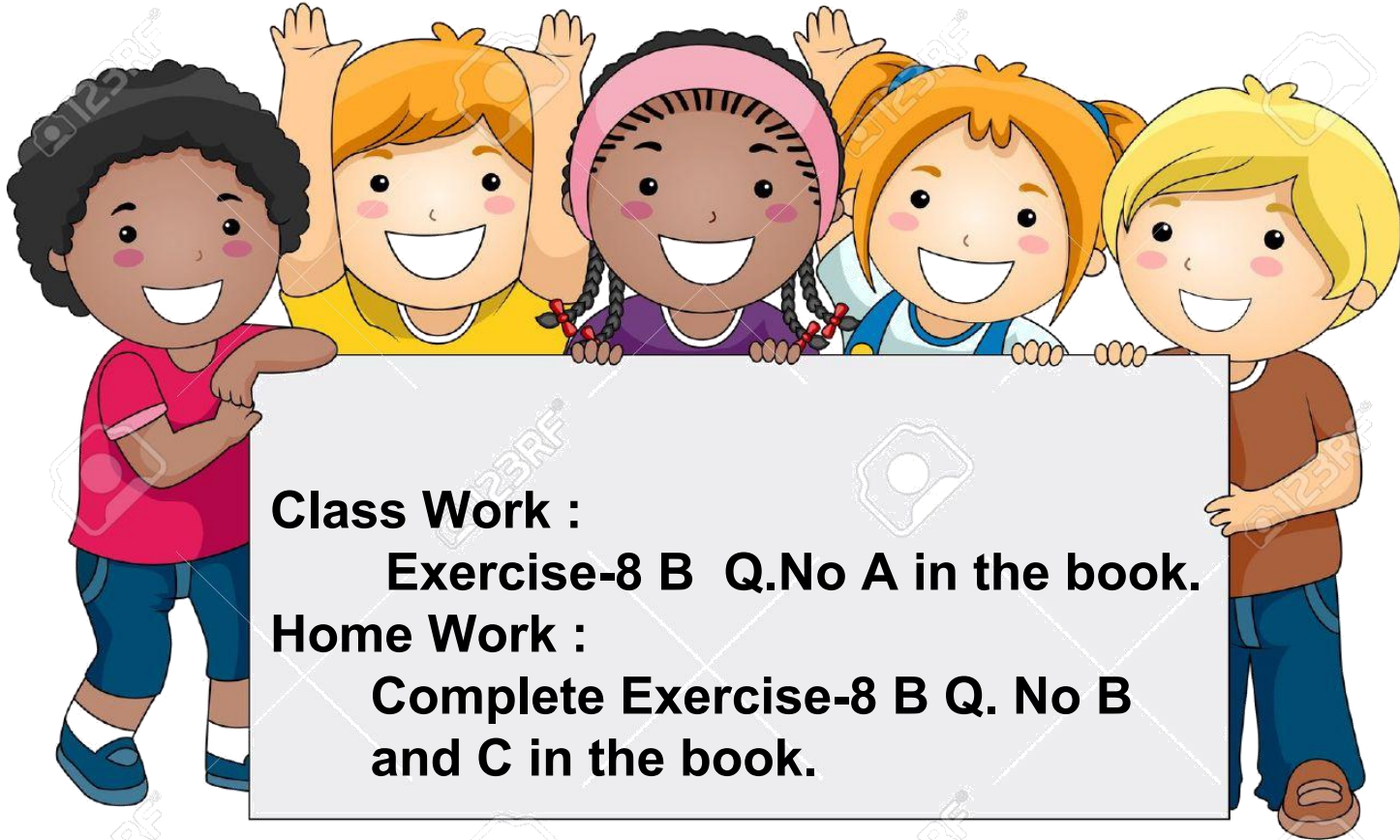

LEARNING OUTCOME:

Children will be able to differentiate between different length of a line, be able to find the length of a line segment. Identify relationship. Measure the length of the given line and draw a line according to the given length.

THANKING YOU
ODM EDUCATIONAL GROUP